

# CONSTRUCTION TECHNOLOGY AND MANAGEMENT

## LECTURE NOTES - B.Tech First year - CIVIL

### UNIT-I:

Construction project management and its relevance - qualities of a project manager - project planning - coordination - Scheduling - monitoring - bar charts - milestone charts - critical Path method (CPM)

### UNIT-II:

Project Evaluation and review technique (PERT) - cost analysis - updating - crashing for optimum cost - crashing for optimum resources - allocation of resources.

### UNIT-III:

Construction equipment - economical considerations - earthwork equipment - trucks and handling equipment - rear dump trucks - Capacities of trucks and handling equipment - calculation of truck production - compaction equipment - types of compaction rollers.

### UNIT-IV:

Hoisting and earthwork equipment - hoists - cranes - tractors - bulldozers - graders - scrapers - draglines - clamshell buckets.

### UNIT-V:

Concreting equipment - crushers - jaw crushers - gyratory crushers - Impact crushers - selection of crushing equipment - screening of aggregate - concrete mixers - mixing and placing of concrete - Consolidating and finishing.

### UNIT-VI:

Construction methods - earthwork - piling - placing of concrete - form work - fabrication and erection - quality control and Safety engineering.

R. Raja Sekhar.

# CONSTRUCTION TECHNOLOGY AND MANAGEMENT

## UNIT-I

\* What is Project Management ?

Project Management is the art and science of converting the client's vision into reality working efficiently, effectively and safely.

(Or)

Project Management is the planning, monitoring and controlling of all aspects of a project and the motivation of all those involved in it to achieve the projective objectives on time and to specified cost, quality and performance.

\* Why Project Management ?

Project Management aim to achieve the assigned goal by managing environment, people and resources. The management principles of planning, organising, staffing, directing, motivating, monitoring, communicating, controlling and decision making apply equally in traditional functional type management as well as project management, but their management philosophy varies considerably. The risks, uncertainties and complexities make project management a relatively difficult process.

# \* CONSTRUCTION PROJECT MANAGEMENT AND ITS RELEVANCE

Project Management is defined as the application of knowledge, skills, tools and techniques to a broad range of activities to meet the requirements of the particular project.

The function of project management includes defining the requirement of work, establishing the extent of work, monitoring the progress of the work and adjusting deviations from the plan.

The elements of Project Management cycle of activities to achieve the project goals.

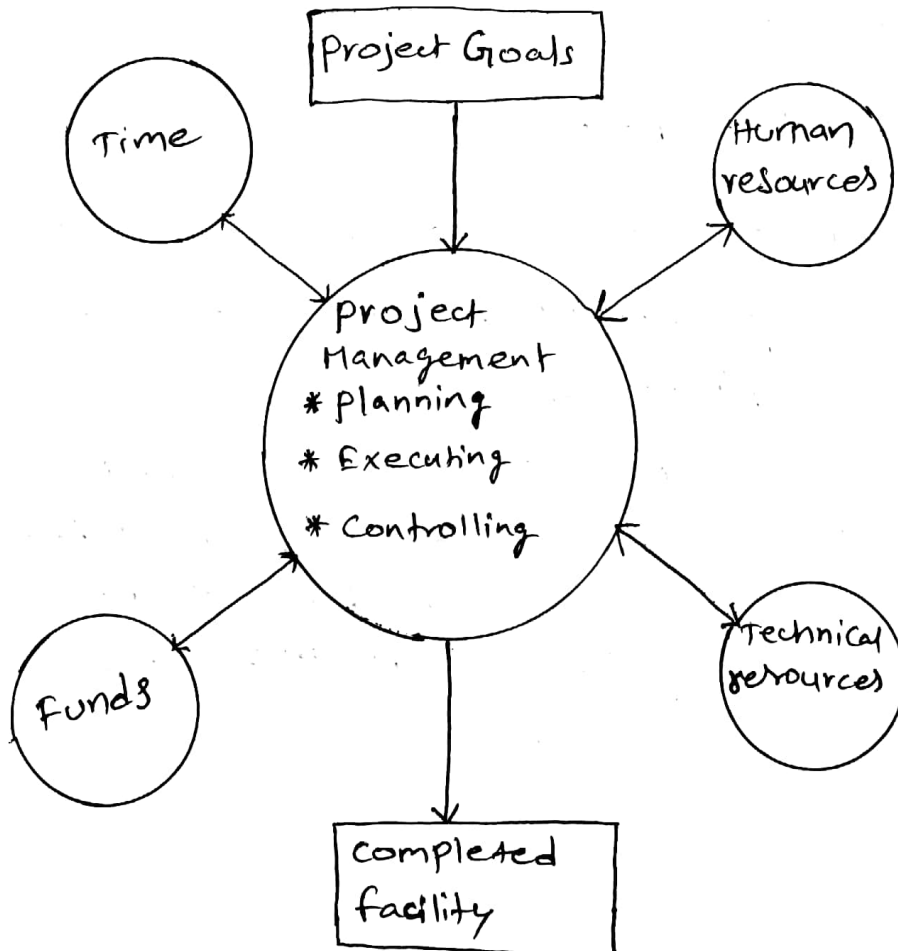

Project management aims to achieve the stated goals of the project leading to completed facility, by virtue of planning, executing and controlling time, funds and human and technical resources. The planning essentially consists of setting objectives, identifying resources and forming strategy.

Execution consists of allocation of resources, guiding execution, coordinating efforts and motivating the staff.

Controlling consists of measuring achievement goals, reporting, and resolving problems.

The planning, executing and controlling are performed on a continuous basis till the goals of the project are realized.

Project management knowledge and practices are best described in terms of their component processes. These processes can be placed into five process groups (Initiating, planning, executing, controlling and closing) and nine knowledge areas

(Project integration management, Project Scope management, Project Time management, Project Cost management, Project Quality management, Project Human Resource management, Project Communications management, Project Risk management, Project Procurement management).

Project management is essentially about managing a project from an idea through to completion. Projects today are getting increasingly complicated than they have ever been, embracing multiple disciplines and included increasingly larger sums of money. The basic ingredient of bringing together ideas and successfully executing them remains, even though the new techniques in project management are continuously being deployed.



## \* OBJECTIVES OF CONSTRUCTION MANAGEMENT:

- (i) Completing the work within estimated budget and specified time.
- (ii) Evolving a reputation for high quality workmanship.
- (iii) Providing safe and satisfactory working conditions for all personnel and workers.
- (iv) Taking sound decisions at the lowest practical management level through delegation of authority.
- (v) Motivating people to give of their best within their capacities.
- (vi) Creating an organisation that works as a team.

## \* QUALITIES OF A PROJECT MANAGER:

Construction projects are managed by individuals, whose work delivers product (or) services, which are the life blood of construction industry. The success of a project hinges on the competency of the project manager.

The project manager is the king pin around whom the whole organisation revolves. He is entrusted with the task of integrating the interdisciplinary and inter-organisational efforts under changing environments for successful accomplishments of the specified objectives. He assumes total responsibility and accountability for the success or failure of the project. His functions may vary with the nature of the project and organisational setup, but his roles which reflect the behavioural patterns are similar in almost all types of project.

## Ten related roles of the project Manager:

- \* Figurehead role: The project manager is the legal and social head of the project. He is the single focal point for making decisions, ceremonial functions and symbolic duties.
- \* Leadership role: As a leader, the project manager directs the interfunctional efforts through a complex web of relationships created in the project's organisation by building a performance-motivated team of skilled and experienced people who collectively face the challenges posed by the environment. In crisis-prone environments, effective leadership is an essential requirement for success and accomplishment of the project mission, but it does assume far greater significance in construction projects.
- \* Liaison role: The project manager maintains contacts outside the organisation, deals with those activities which may involve correspondence and contact with the concerned government and non-government officials, contract vendors, professionals, and top persons of the construction industry.
- \* Monitoring role: The project manager's focus is on the planned baseline for performing tasks, and implementing time, cost and quality planning and monitoring system with a view to motivate the project team to provide assured results.

- \* Disseminator's role: The project manager transmits the relevant information received from external sources and internal systems to the concerned people in the work place. This information may be written or verbal, formal (or) informal.
- \* Spokesperson's role: The project manager acts as the sole representative through whom all communications with the client (or) other external parties are conducted outside the project site.
- \* Entrepreneur's role: The project manager seeks and identifies opportunities to promote improvements and needed changes.
- \* Disturbance handling role: The project manager ~~takes~~ ~~responsibility~~ maintains organisational harmony by resolving conflicts and diagnosing organisational behaviour on time. He applies corrective action when the organisation faces important unexpected disturbances.
- \* Resources allocation role: The project manager takes responsibility for allocating the project resources and makes changes which are necessary to ensure the availability of adequate resources on time. This role also calls for developing and monitoring budgets and predicting future resource needs.
- \* Negotiator's role: The project manager negotiates important conflicting issues and business related matters, both inside and outside of the project environment. He represents the organisation on major negotiations.

## \* Relevance of a Project Manager:

A practical and useful checklist of desirable attributes to form the foundation of trusting relationships between the client and the leader, and the leader and the followers is given below.

- \* Attitude - an open positive 'Can do' attitude.
- \* Common sense - an ability to see things as they really are and to pick sensible, effective, straight forward solutions.
- \* Open mindedness - being open to new ideas, practices and methods.
- \* Adaptability - an ability to anticipate and accept to changes.
- \* Inventiveness - an ability to discover innovative strategies and solutions.
- \* Prudent risk taker - a willingness and ability to identify and understand risks but not to take a risky approach in an unwise or reckless fashion.
- \* Fairness - a fair and open attitude which respects all human values.
- \* Commitment - a very strong overriding commitment to the project's success, user satisfaction and team working. A strong orientation towards goal achievement.

## \* Project planning:

It involves deciding in advance what is to be done, how and in what order it is to be done in order to achieve the objectives. Planning aims at deciding upon the future course of action. A plan shows the committed course of action.

In brief, planning involves the following.

- \* Crystallizing objectives
- \* Collecting and synthesising information.
- \* Developing alternative courses of action within specified constraints.
- \* Comparing alternatives in terms of objectives feasibility and consequences.

## \* Co-ordination;

It is necessary to bring together and coordinate the work of various departments and sections. This requires an efficient system of communication so that each department and section is aware of its role and the assistance to be expected from others. Regular meetings of departmental section heads with top management are fundamental to proper coordination, so that plans, problems and remedies are discussed for determining the best solution.



## \* Scheduling :

It is the fitting of the final work plan to a time scale. It shows the duration and order of various construction activities. It deals with the aspect of 'When to do it'

(Or)

Scheduling is the allocation of resources. These resources, in conceptual sense, are time and energy, but in practical sense are time, space, equipment and effort applied to material.

(Or)

Scheduling is the mechanical process of formalising the planned functions, assigning the starting and completion dates to each part (or activity) of the work in such a manner that the whole work (or project) proceeds in a logical sequence and in an orderly and systematic manner.

## \* Monitoring :

Monitoring helps in providing feedbacks to management on the different schedules prepared earlier, in order to ensure that the project is progressing as per schedule.

The basic objective of any monitoring system is to monitor projects by measuring physical progress, costs and profits against targets, and to help in taking corrective action. It also provides data for preparing reports for management information system (MIS)

## \* SCHEDULING:

Scheduling is the process of fitting the work plan to a time frame indicating the start and completion of each activity. It also shows sequential relationships among various activities. Schedules are also prepared for construction resources such as labour, material, machinery and money required at various stages of the work. The actual progress of each activity can be monitored with reference to the planned programme. If there are any delays, suitable corrective action can be taken to speed up the work.

The construction schedule is a tool that a contractor uses to manage time and execute activities in a proper sequence. To prepare a construction schedule, the project is divided into different activities (or) operations. The sequence of operations can be decided after knowing their inter-relationships as per the construction method adopted. The construction schedule serves the following purposes.

- \* Making available a time-table showing the schedule and sequence of each activity.

- \* providing a schedule for monitoring the progress of work and taking corrective measures, if required.

- \* providing a means for establishing and maintaining time goals and prioritising activities.

## \* Bar charts:

The bar chart is a graphical representation of a project, and given the fact that activities are shown on a real-time scale, they are easy to understand and very useful in reviewing programs. It is one of the oldest methods and an effective technique for overall project planning. These charts were developed by Henry L. Gantt during world war I and, accordingly, these are also sometimes referred to as Gantt charts. They give an idea of duration of activities/project and, hence, can be useful in preparing strategy for working.

In a bar chart, the activities are shown as horizontal bars on horizontal time scale, where the start and end locations of the bars coincide with the start and finish dates of the activities.

Let us consider an example of preparing a bar chart involving the construction of an equipment foundation with set of activities as follows:

| Activities                       | Time (days) |
|----------------------------------|-------------|
| Layout and excavate (foundation) | 5           |
| Place mud-mat (lean concrete)    | 1           |
| fabricate shuttering             | 3           |
| cut and bend reinforcement       | 4           |
| fix reinforcement                | 2           |
| fix shuttering                   | 1           |
| pour concrete                    | 1           |

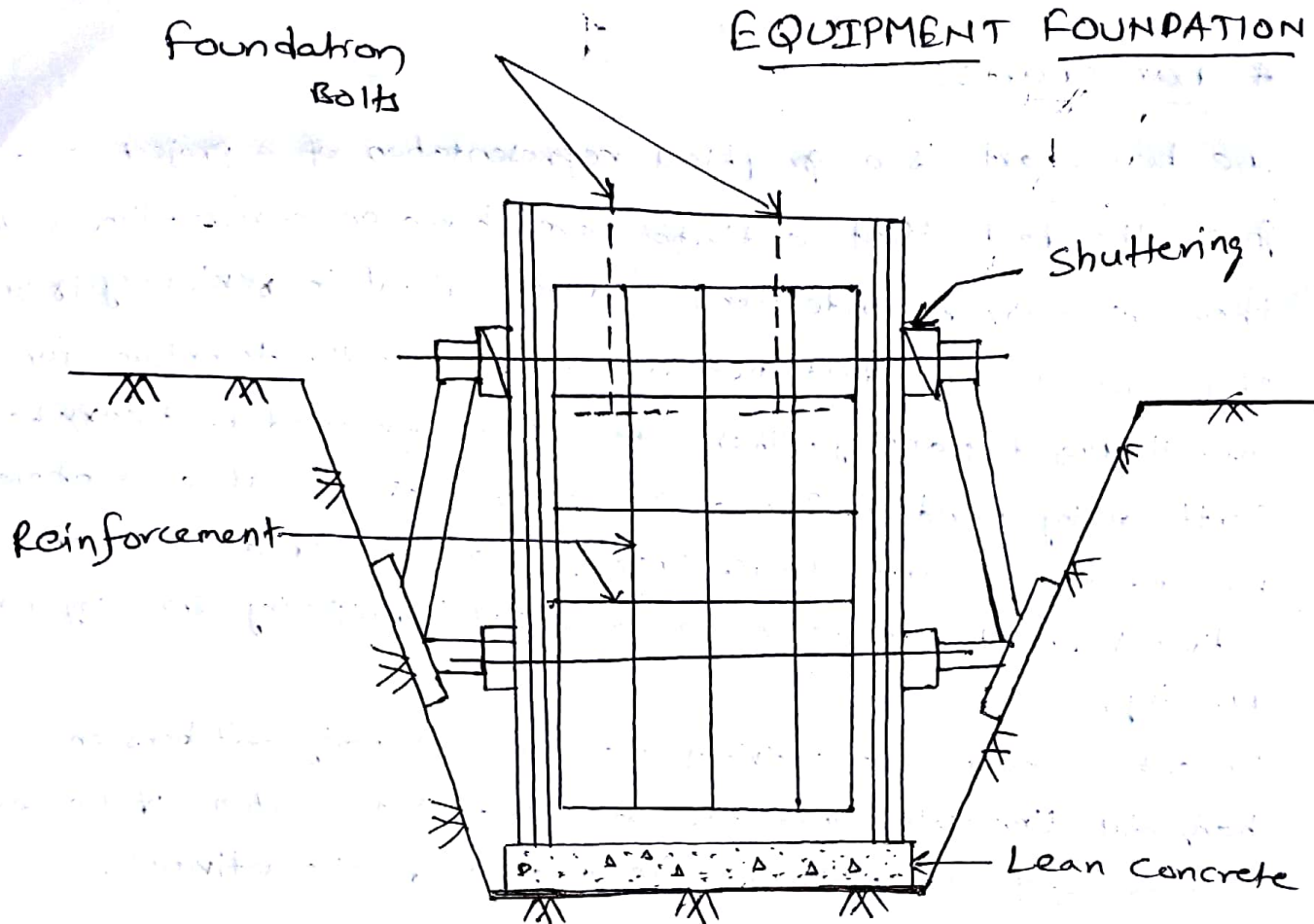

The activities of 'Layout and Excavate foundation', 'fabricate shuttering' and 'cut and bend reinforcement' can start simultaneously as these activities are independent of each other. These activities being concurrent are shown by parallel lines or bars in the chart.

Activity 'place mud-mat (Lean concrete)' can only start after completing the activity 'Layout and excavate foundation'.

These two activities being in series are depicted in the bar chart one after the other. Likewise, 'fix reinforcement' can only be taken up after placing mud-mat (Lean concrete).

'fix shuttering' follows the fixing of reinforcement. These activities, being in series, are shown one after the other.

'pour concrete' is the last activity which follows the fixing of shuttering and being in series, is shown as such in the bar chart.



Bar charts are easy to prepare and to understand. The progress achieved at site in respect of any activity may be shown on the bar chart by drawing a coloured line under the planned bar or line of that activity. The progress achieved is generally indicated on the coloured line as a percentage. Bar charts may, therefore, be used for monitoring the progress of work.

Bar charts may also be used for depicting the resource requirements of a construction job.

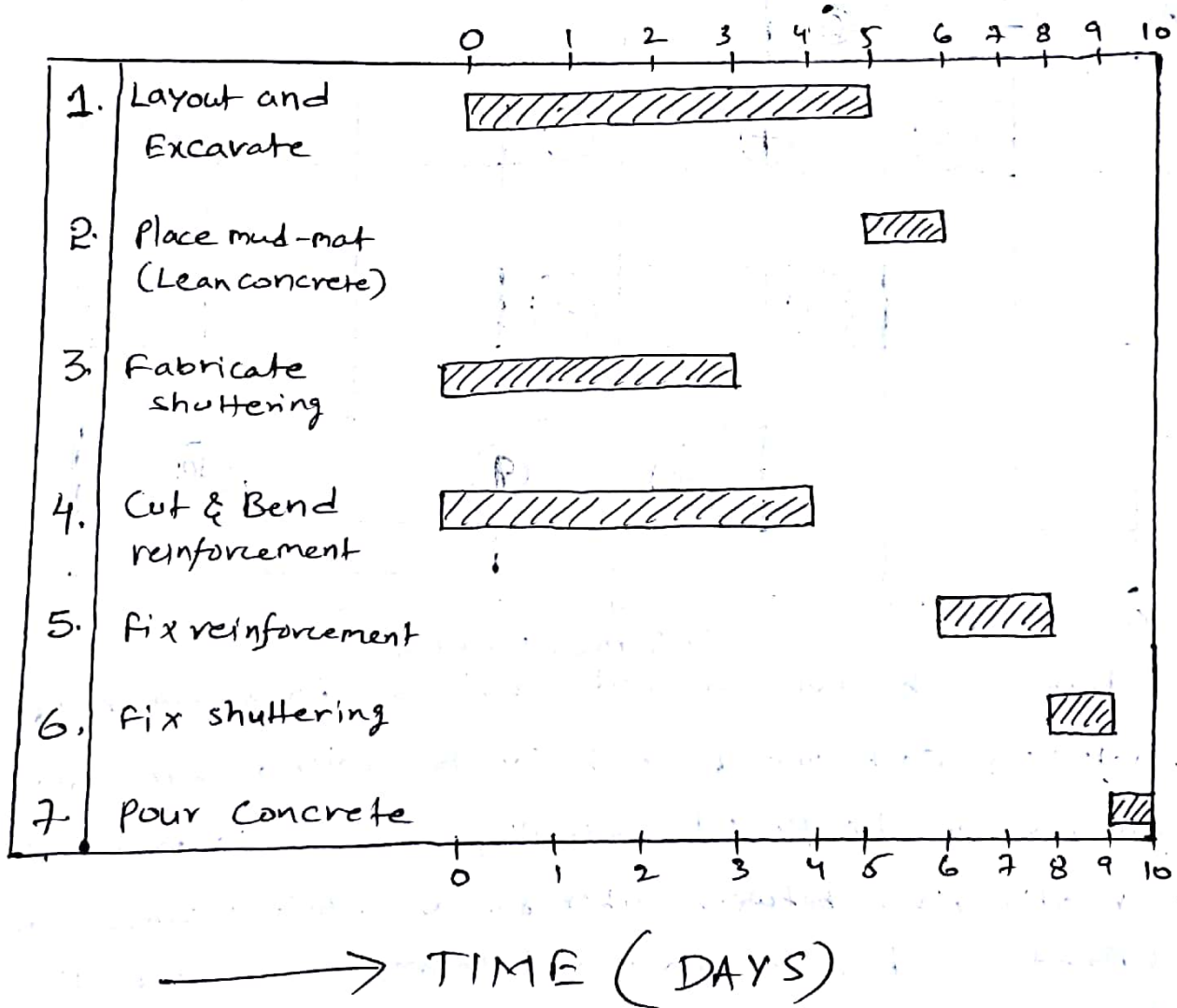

Bar chart for construction of Equipment foundation.



## \* MILESTONE CHARTS

Milestone chart is a modification over the original gantt chart. Milestones are key events of a main activity represented by a bar. There are specific points in time which mark the completion of certain portions of the main activity. These points are those which can be easily identified over the main bar.

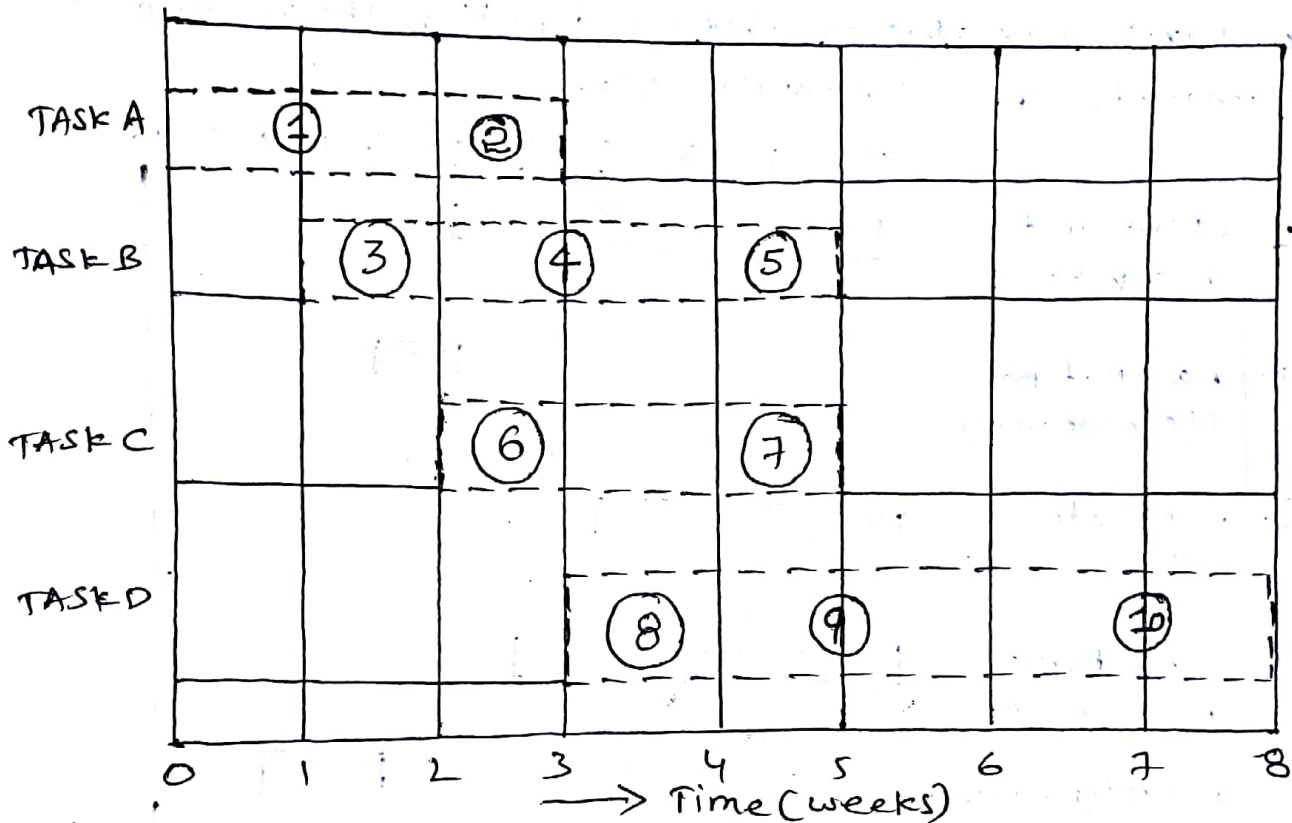

The activity is broken (or sub-divided) into a number of sub-activities, each one of which can be easily recognised during the progress of the project, controlling can be easily done and inter relationships between other similar activities can be easily established. The beginning and end of these sub-divided activities or tasks are termed as milestones. From the above chart some 'milestones' on each bar. Each main task contains some specific points in time which can be recognised, and through which controlling can be achieved. Each milestone can be considered to be specific event along the main activity (or) job (or) task. This chart is, therefore, called the milestone chart. Each milestone is represented either by a circle or by a square, and is serially marked.

## \* CRITICAL PATH METHOD (CPM)

It is a procedure for using network analysis to identify those tasks that are on the critical path i.e., where any delay in the completion of these tasks will lengthen the project timescale, unless action is taken. For all tasks off the critical path, a degree of tolerance is possible (e.g., late start, late completion, early start, etc.). Earlier, CPM analysis was carried out by hand computations. Software is now available to perform CPM calculations.

The following steps are needed in CPM:

- \* List the activities and relationships
- \* Create a start node
- \* Draw arrows from start node to the first activity's node
- \* Sequentially arrange all activities from 'start'
- \* Repeat process from successors for all activities.
- \* Check if there is any relationship that is missing.

In India, CPM is being increasingly used for project management by a number of private and public organisations. Use of CPM provides meaningful answers to such questions as:

- \* What will be the completion time of the project?
- \* If there is a delay in one activity, will the entire project be delayed? if so, by how much?
- \* What is the most economical way to speed up the project?
- \* How to schedule material deliveries so as to have materials when needed but avoid costly storage for long periods?

Application of CPM results in better decisions and a saving in the overall project cost - CPM is extensively used in the construction industry due to the repetitive nature of construction works. This technique is dealt with in detail in the text.

## \* Network Elements:

The two basic elements used in a network are Activity and event. In addition, where necessary, dummy activities are introduced to maintain logic.

Activity: A project can be broken down into various activities necessary for its completion.

It is represented by Arrow  $\longrightarrow$

\* The description of an activity is written ~~at~~ above the arrow and its duration in the middle underneath.

Excavation  
 $\xrightarrow{2}$

An activity involving excavation, and needing two units of time for its completion, would be shown above

\* The length of the arrow is not drawn to scale. As far as possible, the arrow should be sufficiently long so that the description of the activity could be written over it.

\* Arrows are neither curved nor are they drawn in reverse direction.

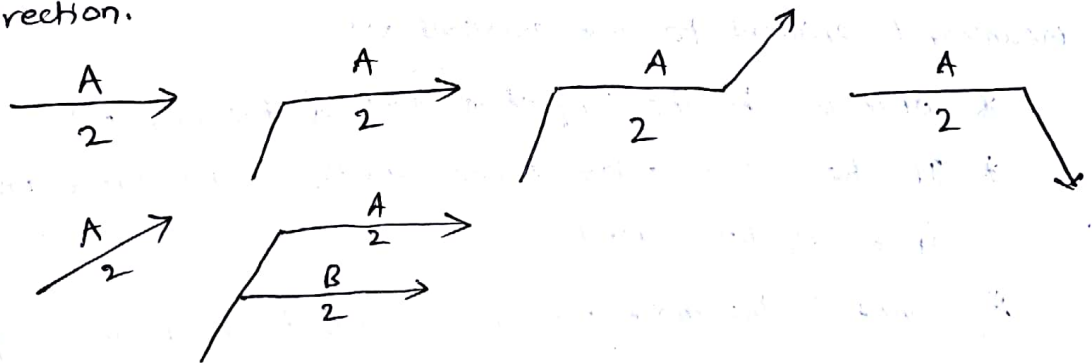

## \* EVENT:

It is the state that marks the completion of a preceding activity and the beginning of the succeeding one. It has no duration; It represents only a point in time; It is represented by a circle (or) an ellipse as

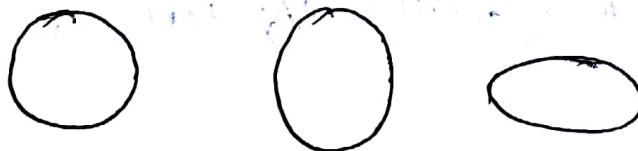



- \* The First event of a project is called the Start event and the Last, the end event.
- \* An event at which an activity starts is termed as the preceding event. The event by which it terminates is called the Succeeding event.
- \* An event of Significance such as 'electrification complete' 'buildings ready for occupation' etc., is called a key event. The occurrence of a key event is termed as the milestone.
- \* A key event common to two or more sub networks is called the interface event.



### \* DUMMY ACTIVITY!

It is a Superimposed activity, which does not represent any specific operation or process. It has zero duration and consumes no resources. Its purpose is

- \* To provide logical link to maintain the correct relationship of activities
- \* To Simplify the description of concurrent activities in terms of event numbers.

The dummy activity is drawn like any other activity, but with dotted lines, as;

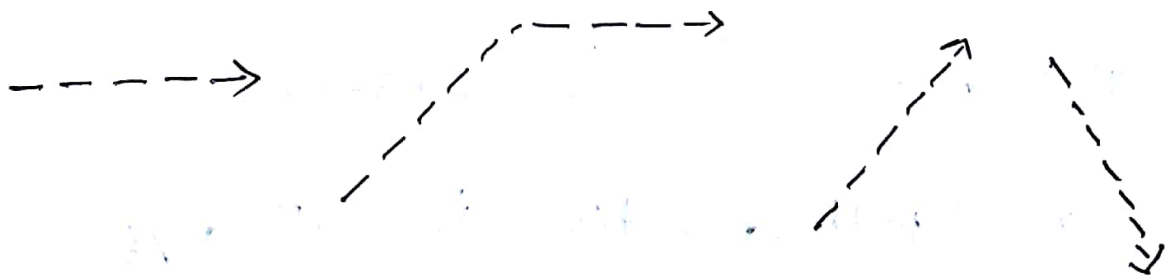

## Problem:

(1) The activity-on-arrow network of activities for a construction project is shown in figure. The durations (expressed in days) of the activities are mentioned below the arrows.

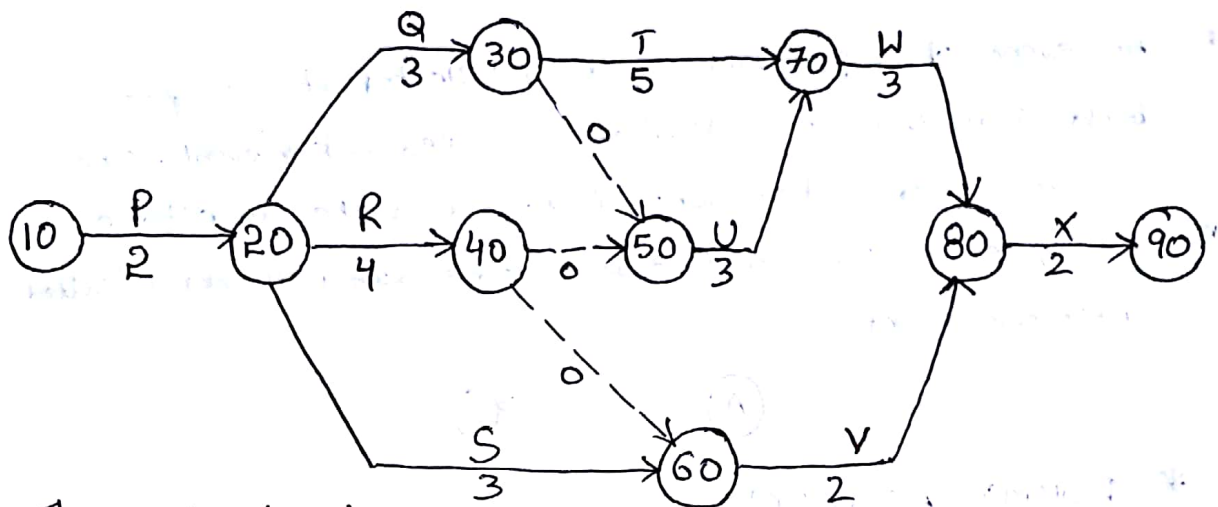

The critical duration for this construction project is

Solution:-

| Path            | Duration           |
|-----------------|--------------------|
| P-Q-T-W-X       | $2+3+5+3+2 = 15$   |
| P-Q-Dummy-U-W-X | $2+3+0+3+3+2 = 13$ |
| P-R-Dummy-U-W-X | $2+4+0+3+3+2 = 14$ |
| P-R-Dummy-V-X   | $2+4+0+2+2 = 10$   |
| P-S-V-X         | $2+3+2+2 = 9$      |

Critical path duration is 15 days.



## UNIT-II

### PROJECT EVALUATION AND REVIEW TECHNIQUE (PERT)

PERT is more commonly used in the manufacturing industry, especially in the research and development types of programmes. It is assumed that activities and their interdependence are well-defined, though it recognizes uncertainty in the time estimate of an activity. PERT incorporates uncertainties in activity durations in its analysis, requiring three durations for each activity, which are the most probable:

Optimistic time estimates ( $t_o$ )  
Pessimistic time estimate ( $t_p$ )  
Most likely time estimate ( $t_m$ )

} for completing an activity.

Optimistic time estimates ( $t_o$ ) is the shortest possible time for completing an activity if everything proceeds as planned without any problem i.e. the activity is performed under ideal conditions.

Pessimistic time estimate ( $t_p$ ) is the maximum time required to complete an activity under abnormal or extremely adverse conditions in which every thing goes wrong. The estimate, however, does not include catastrophes such as fires, earthquakes, floods etc.

Most likely time estimate ( $t_m$ ) is the time for completing an activity under normal conditions. In this case, conditions are not ideal and minor mishaps may occur.

The expected time estimate for each activity is computed on the basis of statistics as under:

$$t_e = \frac{t_o + 4t_m + t_p}{6}$$

Problem: The optimistic time (O), most likely time (M) and pessimistic time (P) (in days) of the activities in the critical path are given below in the format O-M-P

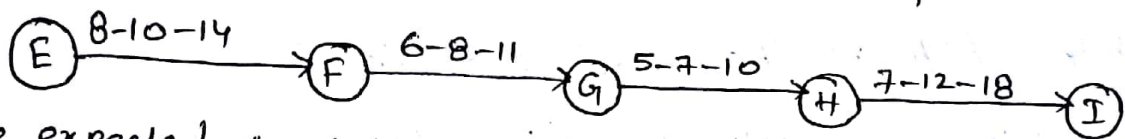

The expected completion time (in days) of the project is ?

Solution:-

| Activity | Expected Duration<br>$t_e = \frac{t_o + 4t_m + t_p}{6}$ |
|----------|---|
| E-F      | $= \frac{8 + 4(10) + 14}{6} = 10.33$                    |
| F-G      | $= \frac{6 + 4(8) + 11}{6} = 8.16$                      |
| G-H      | $= \frac{5 + 4(7) + 10}{6} = 7.16$                      |
| H-I      | $= \frac{7 + 4(12) + 18}{6} = 12.16$                    |

Expected completion time of the project

$$= 10.33 + 8.16 + 7.16 + 12.16$$

$$= 37.81 \text{ days} \approx 38 \text{ days}$$

## \* Importance of Time-cost Analysis:

The main objective of network planning is to complete the job within the stipulated time and at minimum overall cost.

At times it becomes necessary to accelerate the completion of work. This can be made possible only by reducing the duration of critical activities. The duration of critical activities can be reduced by the deployment of additional resources e.g. additional Labour, shuffling, centring etc. while exploring the possibility of accelerating project completion by deploying additional resources on critical activities.

Project cost depends upon the time available for completing the work and the time in which a project may be completed depends upon the cost that the owner is prepared to bear. Cost and time being inter-related, a scientific analysis of project cost for different time periods of completion assumes paramount importance in project planning and implementation.

## \* PROJECT COST:

The project cost can be broadly divided into

- (i) Direct cost
- (ii) Indirect cost

\* Direct cost consists of expenditures which are directly chargeable to and can be identified specifically with the activities of the project e.g. material cost and labour cost

\* Indirect cost consists of expenditures which cannot be clearly allocated to individual activities of the project e.g. establishment charges, insurance charges, administration charges etc.,



## \* UPDATING:

It can be defined as planning and programming of the remaining portion of an activity job by introducing the latest information available.

At the end of any day of work, the activities of the project must either be completed, in progress, or they may not have started yet. Further, the actual progress may not be according to the originally envisaged schedule. Also, some of the activities that must have been completed as on the day of updating may not have been completed; worse still, some may not have started. Some of the activities may not have achieved the required percentage of progress that was planned on the day of updating. It is also possible that some new activities that were not in the original plan might have to be taken up. This may at times bring about a change in the network logic (sequencing of events). All these situations require updating of a project plan at an appropriate interval or frequency.

(OR)

- \* If all activities are progressing according to the schedule, there is no need for updating the network but this is seldom the case. Therefore, based on the progress of the work and the revised durations of unfinished activities due to delays, the network diagram has to be redrawn and this process is known as updating.
- \* The process of replanning and rescheduling based on the results which serve a guidance for decision by performing calculations made by taking into consideration the new knowledge and latest information at an intermediate stage of the project thus modifying the original network, is known as the process of updating.

## \* DATA REQUIRED FOR UPDATING;

The following information is necessary to update the plan at an intermediate stage of execution of a project:

1. Original network
2. Original network calculation chart
3. Stage at which updating is ~~done~~ being done i.e., a point in time of updating.
4. Execution position of the project at the stage and
5. New information and knowledge which will affect the duration time of the activities to be performed.

\* The following steps are suggested:

1. All completed activities are given zero duration.
2. All activities in progress are given duration equal to the number of days remaining for completion.
3. All activities not yet started are given duration as reported in the latest estimate.
4. Any correlation change i.e., changed network logic between activities (or parts thereof, yet to be completed are brought forth and necessary changes in the arrow network diagram are duly envisaged, discussed and communicated/recorded.
5. To keep up the calendar scheduling of the time baseline unchanged and also keep the facts as they are the earliest occurrence time of the first activity of the network being updated is marked as, say,  $x$ , where  $x$  is the day on which the network is being updated. For example, if the updating is done at the end of the 15th day (i.e. if the updated activity are to be begin on the morning of the 16th day) the early occurrence time of the 1st activity would be marked as 15.
6. New critical paths are then computed for further control/monitoring.



## UPDATING CYCLE

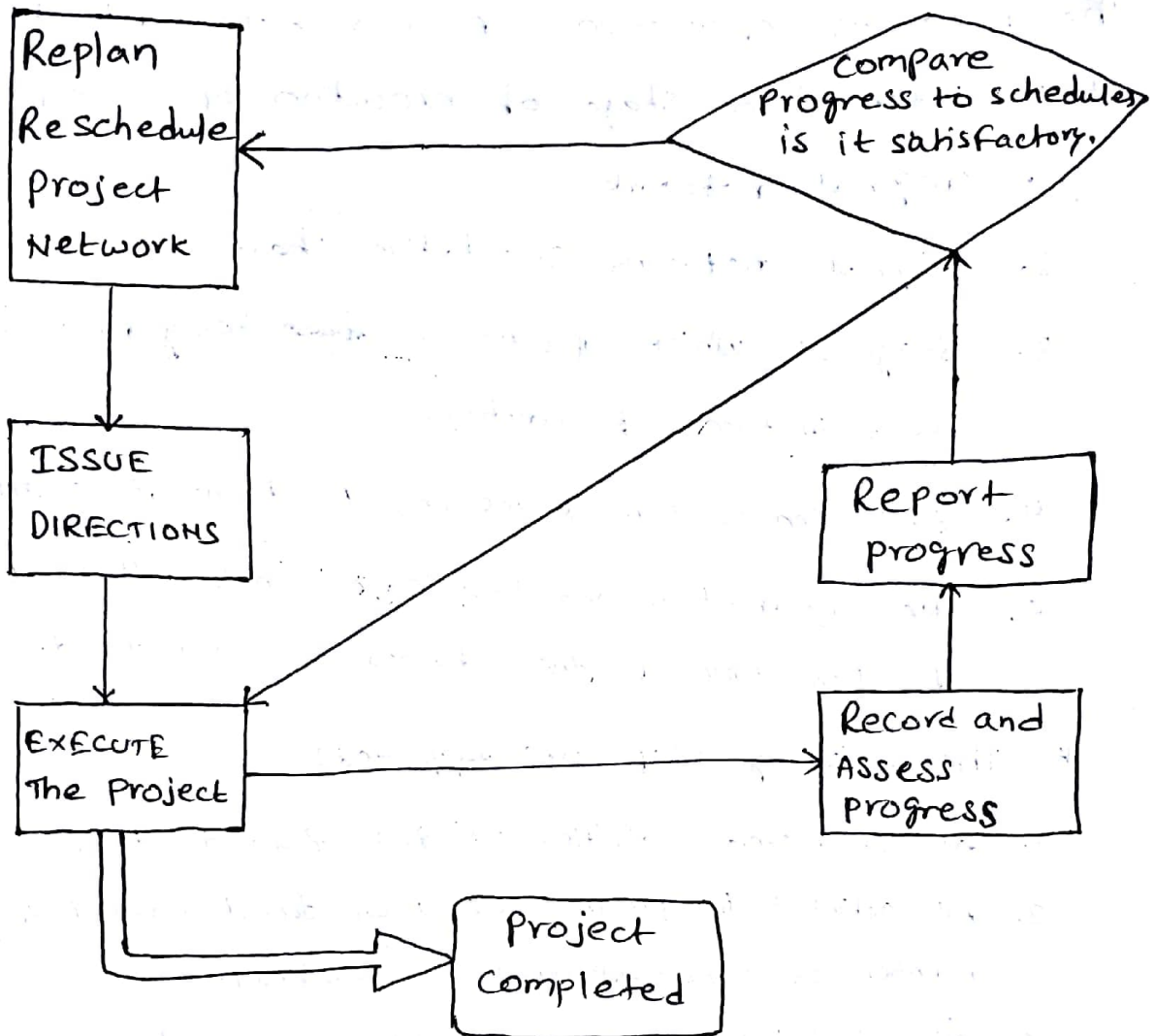

### \* WHEN TO UPDATE

1. For shorter duration projects, the updating must be done frequently by taking into account the latest position of the execution of the project.
2. For large duration projects, the process of updating must be increased as the project is progressing toward completion. Duration of project goes on decreasing as project progresses, and behaving more or less like a small duration project.
3. Whenever there is major change in the duration of any of the activity the updating is to be done.
4. Updating is essential if there is change in the estimated duration of any activity falling on the critical path. If the duration of a critical activity increases, remedial measures are necessary and if the activity duration decreases, this may allow changes in the project plan which were not possible previously.

## \* COST OPTIMIZATION:

The total cost vs. time curve can be obtained as the below shown figure, by plotting both the direct cost and indirect cost curves with respect to time on the same graph sheet and combining them.

The curve for total cost has a point where the tangent is horizontal. At this point, the total cost is minimum and is called the 'optimum cost'. The time duration corresponding to the optimum cost is called 'optimum time'.

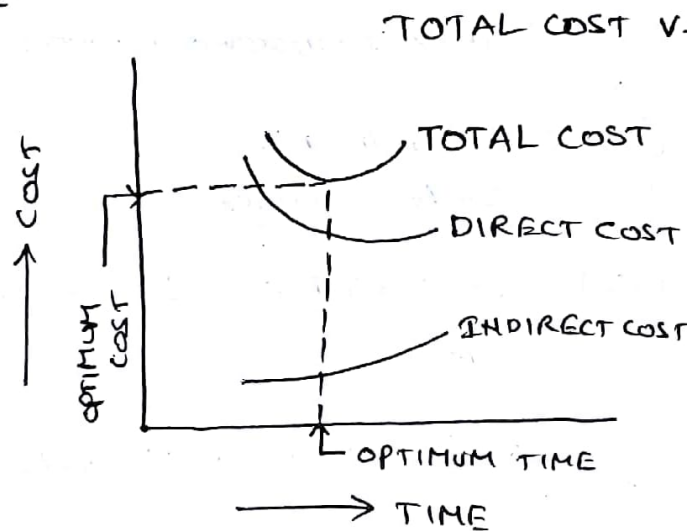

## \* PROCEDURE FOR COST OPTIMIZATION

- 1) From past project cost records, determine the cost-time relationship for different activities. Calculate the cost slopes of the various activities.
- 2) From the network of normal durations, determine the total cost (direct cost + indirect cost).
- 3) Prepare the 'all crash' network and determine the total cost.
- 4) The optimum duration will generally lie between all crash duration and normal duration. Starting with the network of normal durations, crash the critical activity with the least cost slope.
- 5) Redraw the network considering the above crashing and determine project duration and total cost.
- 6) Successively, keep on crashing critical activities as in (4) above and determine respective project durations and total costs. In case more than one path becomes critical, crashing will have to be done along all such critical paths, simultaneously.

7) Tabulate various project durations and the corresponding total costs. Draw the total cost vs time curve.

8) The least total cost is the optimum cost and the time duration corresponding to this cost is the optimum duration.

**Normal Time ( $T_n$ ):** It is the time for performing an activity with the normally available resources.

**Normal cost ( $C_n$ ):** It is the minimum direct cost when the activity is performed in normal time duration.

**Crash time ( $T_c$ ):** It is the minimum time in which an activity can be performed.

**Crash cost ( $C_c$ ):** It is direct cost corresponding to the crash time.

$$\text{Cost slope} = \frac{\text{Crash cost } (C_c) - \text{Normal cost } (C_n)}{\text{Normal Time } (T_n) - \text{Crash Time } (T_c)}$$

$$= \frac{\text{Difference between crash \& Normal cost}}{\text{Difference between Normal \& crash Time}}$$



## \* ALLOCATION OF RESOURCES

A resource is a physical variable, such as men, materials, machines, space, money that is required for completing various activities/jobs of a project. The network analysis for PERT/CPM, carried out so far is valid only if the availability of resources is liberal or unlimited. But all the necessary resources are not available in unlimited quantities. Availability of some of the resources may be restricted. Availability of Manpower (supervisory staff, technical and specialist personnel, skilled and unskilled labour etc.) and materials etc. may be restricted. Availability of funds, credits, capital investments and heavy equipment may be restricted. In capital investment certain cases, there may be space limitations, which prevent more than one or two technicians working simultaneously. Supervisory, technical and skilled manpower, space and equipment are usually the most important resources that need be allocated carefully.

The various activities of the project are to be scheduled in such a way that the demand of various resources is more (or) less uniform all along the project duration. Large fluctuations in their demand may cause problems in the project execution.

### \* TWO METHODS TO SOLVE RESOURCE ALLOCATION PROBLEM

(i) Resources Smoothing.

(ii) Resources Levelling.

In the first approach known as resources smoothing method, the total project duration is not changed, but some of the activities start times are shifted by their available floats so that a uniform demand for the resources is generated. However, the resources are considered to be unlimited.



In the second approach, known as Resource levelling, the activity start times are so re-scheduled that the peak demand for a particular resource does not cross the available limit of the resources. Thus, the resources are considered to be limited. In rescheduling the activities, the floats are first used, but if that does not give the desirable results, the total project duration may be changed.

### RESOURCES SMOOTHING:

This is the first approach of solving the resources allocation problem, in which the resources are considered to be unlimited. The original project duration (i.e. duration along the critical path) is however maintained. The start times of some of the activities are so shifted within their available floats that uniform demand is created for the resources.

To illustrate the procedure, let us consider the network of having 14 activities. The duration of each activity is marked under its activity arrow. The early event times and late event times are marked near each event circle. The critical path is along activities 1-2, 2-4, 4-7, 7-9, 9-11, 11-12 shown by thick lines.

| Activity | Duration | Masons (M) | Labourers (L) |
|----------|----------|------------|---------------|
| 1-2      | 2        | 1          | 2             |
| 2-3      | 3        | 3          | 2             |
| 2-4      | 4        | 1          | 2             |
| 2-5      | 2        | 2          | 3             |
| 3-10     | 4        | 3          | 2             |
| 4-6      | 2        | 3          | 2             |
| 4-7      | 4        | 5          | 3             |
| 5-9      | 4        | 1          | 3             |
| 6-8      | 2        | 1          | 2             |
| 7-9      | 5        | 1          | 3             |
| 8-9      | 3        | —          | 4             |
| 9-11     | 2        | 1          | 1             |
| 10-11    | 3        | 1          | 2             |
| 11-12    | 2        | 1          | 2             |

\* Table Shows the requirements of masons (M) and Labourers (L) for each activity. Let us analyse the project from resources requirements point of view. We find that the peak requirements of masons are there are on 7th and 8th day. Also, the requirements of masons on 5th and 6th day is high. Also, the requirements of mason on 11th day and onwards is very low.

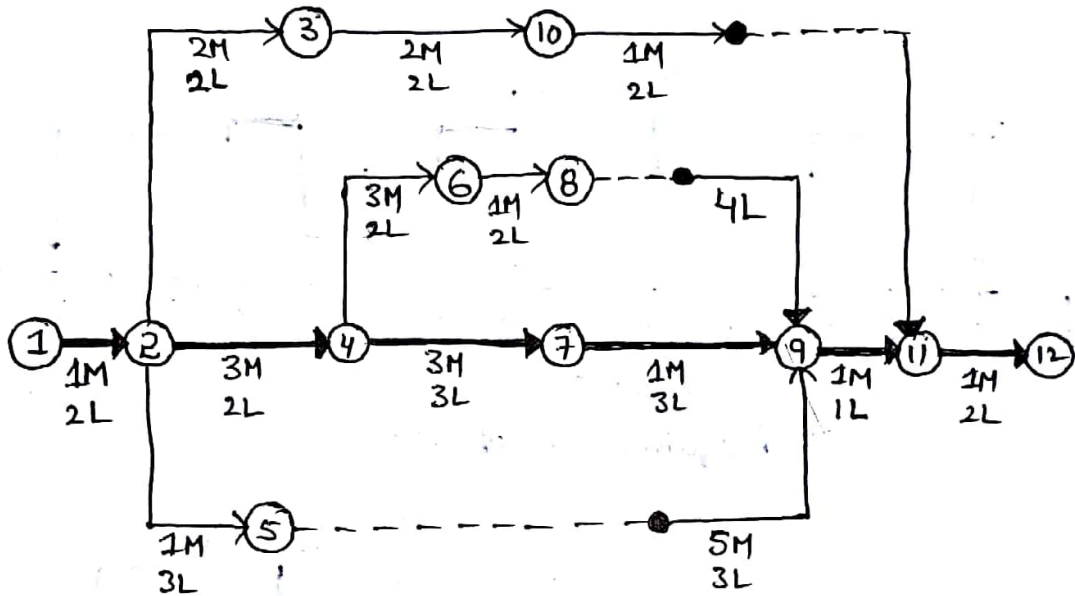

By inspection, we find the activities 1-5 and 5-9, have a total float of 7 days. Hence the start time of activity 5-9 can be shifted by 7 days. This will give encouraging results since this activity requires 5 masons. As a first trial therefore, let us shift activity 5-9 by 7 days, so that it starts on 12th day instead of 5th day.

|   |   |   |   |   |   |   |   |   |   |   |   |   |    |    |    |   |   |   |   |
|---|---|---|---|---|---|---|---|---|---|---|---|---|----|----|----|---|---|---|---|
| M | 1 | 1 | 6 | 6 | 5 | 5 | 8 | 8 | 6 | 5 | 2 | 7 | 6  | 6  | 6  | 1 | 1 | 1 | 1 |
| L | 2 | 2 | 7 | 7 | 4 | 4 | 7 | 7 | 7 | 7 | 5 | 8 | 10 | 10 | 10 | 1 | 1 | 2 | 2 |

This shows revised network, along with the modified resources accumulation table. We find that the peak demand for masons has decreased from 13 (for 7th & 8th day) to 8 (for 7th & 8th day). Also, the demand of masons has decreased from 10 to 12.

In the second trial, we can shift activity 8-9 by its total float period of 2 days. This will result in smoothing the labour requirements.

We observe that the demand of labourers has been decreased from 12 to 10. It shows the corresponding histograms for the masons and the labourers. Thus following this procedure, it is always possible to smoothen the resources requirements, without affecting the project duration.

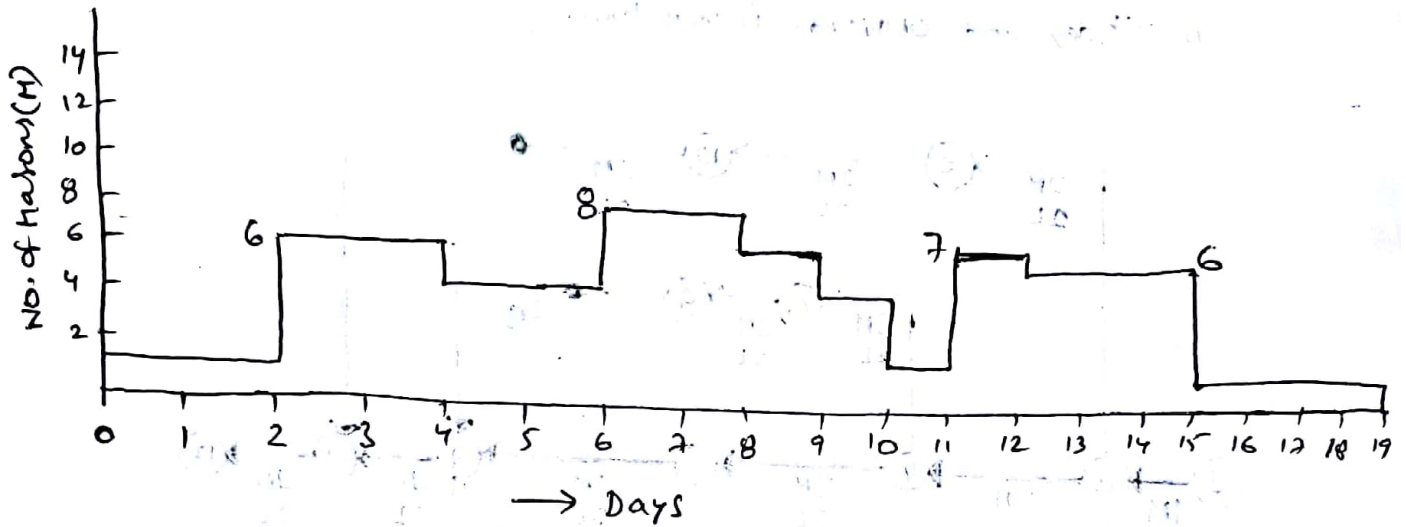

(a) Requirement of Masons.

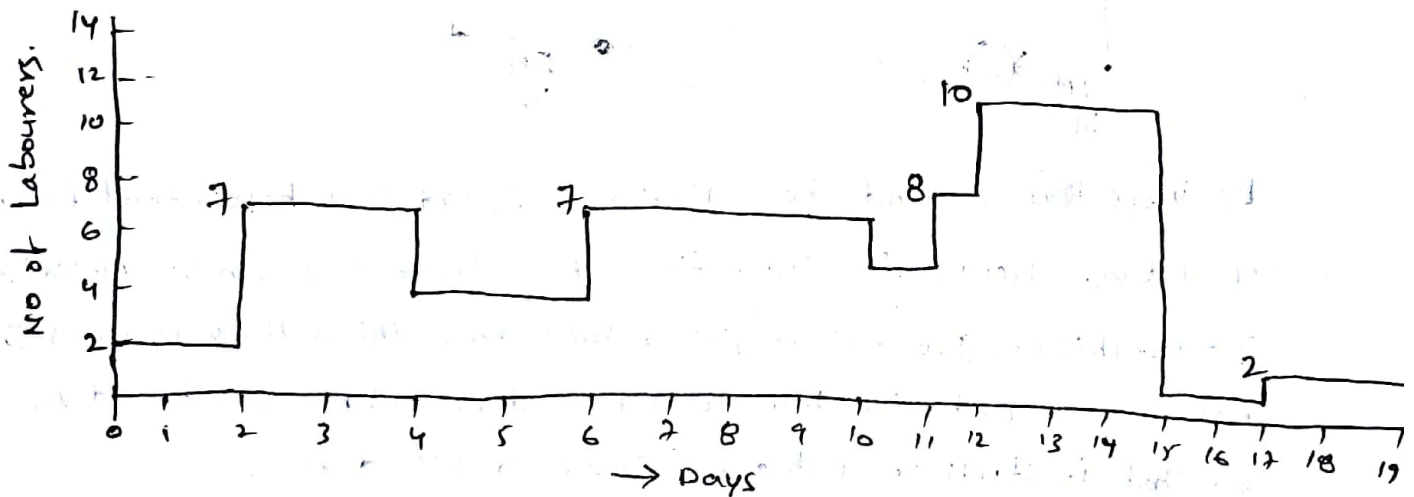

(a) Requirement of Labourers.

\* RESOURCES LEVELLING: The activities are so rescheduled that the maximum or peak resources requirement does not cross the limit of available resources. The available resources should, however, not be less than the maximum number (or) quantity required for any activity of the project. In rescheduling, the available floats are first used. If by doing so, the resources demand is more than the available resources, the duration of some of the activities is increased so that the resources requirements for these activities is decreased. Thus in the resources levelling process, the project duration, initially planned, might be changed.



## UNIT - III

### CONSTRUCTION EQUIPMENT

- \* Construction equipment plays a significant role in the execution of modern high-cost time bound construction projects. An indispensable item of resources, it produces output at accelerated speed, and enables completion of tasks in a limited time. Equipment saves manpower, which is becoming scarce, costly and more demanding day-by-day. Equipment improves productivity, quality and safety.

The nature of production tasks which can be performed with equipment include excavating, hauling, transporting, compacting, grading, hoisting, concreting, precasting, plastering, finishing, trenching, pipe-laying, cable-laying and so on. In addition, the support equipment at the project site consists of generators, pumping sets, treatment plants and other utilities services equipment.

Construction equipment planning aims at identifying the construction equipment for executing project tasks, assessing equipment performance capability, forecasting the date wise requirement of numbers and types of equipment, and finally participating in the selection of the equipment to be acquired.

#### \* ECONOMIC CONSIDERATIONS:

The economic considerations such as owning costs, operating labour costs and operating fuel costs of equipment are most important in selection of equipment. Besides, the resale value, the replacement costs of existing equipment, and the salvage value associated with the equipment are also important. The economics of equipment selection and replacement issues are dealt with in detail in later parts.



## COMPANY-SPECIFIC

The selection of equipment by a company may be governed by its policy on 'owning' or 'renting'. While emphasis on 'owning' may result in purchase of equipment keeping in mind the future requirement of projects, the emphasis on 'renting' may lead to putting too much focus on short-term benefits. This may explain the situation of a construction company opting for two 30 m<sup>3</sup>/h batching plant owned by the company and currently idle, instead of the required one 45 m<sup>3</sup>/h batching plant that it can get on rent. It is clear that the company wants to deal with the 30 m<sup>3</sup>/h batching plant keeping future projects in mind, even though going for the 45 m<sup>3</sup>/h batching plant option at present may have been economical.

Further, if the company project forecast says that there will be considerable number of projects involving a particular type of construction equipment, say X, for the next couple of years, then the decision would be to buy only this type of equipment. A construction company specializing in a particular type of construction, such as tunnelling, will have a tendency to procure only those equipments that are used in tunnel construction. The equipment-selection decision also depends on the amount of outsourcing the company does to execute its projects. A company opting to subcontract a majority of their project work will tend to keep low equipment asset.

## SITE-SPECIFIC

Site conditions - both ground conditions as well as climatic conditions - may affect the equipment-selection decision. For example, the soil and profile of a site may dictate whether to go for a crawler-mounted equipment or a wheel-mounted equipment. If there is a power line at or in the vicinity of site, one may go for a fixed-base kind of equipment rather than a mobile kind of equipment. Similarly, climatic conditions such as the presence of strong winds, visibility level and noise level may affect equipment-selection decision.

Further, the access leading to the site may also affect the decision. Heavy traffic congestion near a site may lead to a decision to produce the concrete at site and, hence, selecting a concrete batching plant rather than relying on ready-mix concrete. Similarly, if there is only a narrow road leading to the site, it may have a bearing on type of transportation equipment selected for the site.

### EQUIPMENT - SPECIFIC:

Construction equipments come with high price tags. While it may be tempting to go for the equipment with low initial price, it is preferable to opt for standard equipments. Such equipments are manufactured in large numbers by the manufacturers, and their spare parts are easily available, which would ensure minimum downtime. Besides, they can also fetch good salvage money at the time of their disposal.

It is a general tendency to go for such equipments that can bring in 'uniformity' in the type of equipments that are already available with the company. For example, a company would like to go for a uniform type of engines for different machines such as excavators, dumpers and tractors.

The size of equipment selected is also an important consideration. Although the unit production cost may be cheaper for equipments of large size, it is also true that large equipments require correspondingly larger sizes of matching equipments. Thus, downtime in one primary unit may lead to downtime in dependent equipments also. A trade-off between unit production costs versus size must be obtained, and as far as possible equipments of similar sizes should be selected for the project.



### Client-and Project Specific;

The owner/client in a certain project may have certain preferences that are not in line with the construction company's preferred policies as far as equipment procurement is concerned. The schedule, quality and safety requirements demanded of a particular project may in some cases force the company to yield to the demands of the client.

### Manufacturer-specific;

A construction company may prefer to buy equipment from the same manufacturer again and again, and that too from a specific dealer. This may be to bring in uniformity in the equipment fleet possessed by the company or because the company is familiar with the working style of the manufacturer and the dealer. Long association may not only result in cheaper price, but it also ensures prompt services by the manufacturer with regard to the company.

### Labour consideration;

Shortage of manpower in some situations may lead to a decision in favour of procuring equipment that is highly automated. Further, the selection of equipment may be governed by the availability or non-availability of trained manpower. The company may not be inclined to select some sophisticated equipment if it finds that there is limited availability of manpower to operate the same.

## \* EARTHWORK EQUIPMENT:

- (i) Excavation and lifting equipment - backactor (or backhoes), face shovels, draglines, grabs (or) clamshell and trenchers.
- (ii) Earth cutting and moving equipment - bulldozers, scrapers, front-end loaders
- (iii) Transportation equipment - tippers, dump truck, scrapers rail wagons and conveyors.
- (iv) Compacting and finishing equipment - tamping foot rollers, smooth wheel rollers, pneumatic rollers, vibratory rollers, plate compactors, impact compactors and graders.

In order to plan the number of earthwork equipment needed, the planner first determines the following:

1. The suitable class of equipment for earthwork - for example, if the soil to be excavated is loose and marshy, and bulk excavation is involved in the project, one may opt for a dragline. The planner needs to be familiar with different classes of equipment used in earthwork and their suitability of working in different conditions.

### \* Backhoe: (i) for excavation below the ground (lower elevation)

- (ii) Applied for cutting of trenches, pits, etc., levelling & loading
- (iii) Suitable for heavy positive cutting
- (iv) struck bucket capacity  $0.38 \text{ m}^3$  to  $3.25 \text{ m}^3$

### \* Shovel (or) Front shovel: (i) for excavation above its own track (or) wheel level.

- (ii) For cutting and for loading
- (iii) suitable for heavy positive cutting in all types of dry soil.
- (iv) struck bucket capacity  $0.38 \text{ m}^3$  to  $3.25 \text{ m}^3$



- \* Dragline: (i) For bulk excavation in loose soils below its own track level.
- (ii) for canals and pits excavation, cutting and desilting of ditches.
- (iii) Suitable for loose soils, marshy land and areas containing water.
- (iv) Capacity of ~~stms~~  $0.38\text{m}^3$  to  $3.06\text{m}^3$
- \* Clamshell (or) grab: (i) for deep confined cutting in pits, trenches
- (ii) Applied for shafts, pits, wells.
- (iii) consists of a hydraulically controlled bucket suspended from a lifting arm,
- (iv)  $0.38\text{m}^3$  to  $3.06\text{m}^3$ .
- \* Dozers: (i) For moving earth up to a distance of about 100m, shallow excavation, and acting as a towing tractor and pusher to scraper machines.
- (ii) clearing and grubbing sites, excavation of surface earth, and maintaining roads.
- (iii) Can be track-mounted (or) wheel-mounted.
- (iv) Blade capacity  $1.14\text{m}^3$  to  $6.11\text{m}^3$ .
- \* Roller compactor: (i) for compaction of earth (or) other materials.
- (ii) used for large works of highways, canals and airports.
- (iii) comes in different varieties such as (1) smooth-wheeled roller (2) vibratory roller (3) pneumatic-tyred roller (4) sheep-foot roller.
- (iv) For (1) 8-10t (2) 14-17t (3) 11-25t (4) 2.5 to 11.5t Capacity can be increased by ballasting.
- \* Scraper: (i) For site stripping and levelling, loading, hauling & discharging over long distances.
- (ii) Comes in different varieties such as towed scrapers, two-axle scrapers and three-axle scrapers.
- (iii) Best suited for haul distances varying between 150m and 900m
- (iv) Sizes varying from  $8\text{m}^3$  to  $50\text{m}^3$

- \* Dumper (i) for horizontal transportation of materials on & off sites
- (ii) suitable for hauling on softer subgrades; Large Capacity dumpers are used in mines and quarries.
- (iii) comes in different varieties with front tipping, side tipping, (or) elevated tipping arrangements.
- (iv) Load capacity of 1t to about 80t; 20t is common for small dumper.

- \* Grader :- (i) for spreading fill and fine trimming the sub-grade. grader performs a follow-up operation to scraping (or) bulldozing
- (ii) Grading and finishing the upper surface of the earthen formations and embankments.
- (iii) Graders usually operate in the forward direction.

### \* TRUCKS :

These are classified on the basis of method of dumping the load

#### 1. DUMP TRUCKS

(a) Side (or) Rear dump trucks

(b) Bottom dump trucks

#### 2. DUMPERS

### \* DUMP TRUCKS :

- These are used for earth moving purpose
- The selection of the type of dump trucks for a specific job depend on the soil condition.

### (a) Side or Rear dump trucks;

\* These are heavy duty trucks with strongly built body which is hinged on the truck chassis at the rear end and one side respectively, and can be fitted to the rear in the case of rear dump and to the hinged side in case of the side dump, through the action of hydraulic jacks.

\* These trucks are suitable for use in hauling wet clay, sand, gravel, quarry rocks etc,

### (b) Bottom dump trucks;

\* These are similar to semi-trailers in which their front is supported on the rear of the hauling tractor and their rear is resting on their own wheels.

\* The body of the truck remains in the same position and discharge of the material takes place through its bottom after opening of two longitudinal gates.

\* The gates are hinged to the side of the body.

\* These trucks are suitable for use in hauling free flowing material. such as, sand, gravel, dry earth, hard clay, etc,

### DUMPERS;

\* High speed pneumatic wheeled trucks.

\* Short chassis.

\* Strong bodies

\* Loading, hauling and dumping is done very fast as compared to other equipment

\* Suitable for short hauls on rough roads.

\* specially where a shuttle movement is required.



## \* CRANES FOR MATERIAL HANDLING

cranes are predominantly used for handling including lifting, lowering and swing shifting of small to heavy loads. cranes come in many types such as crawler-mounted mobile cranes, self propelled rubber-tyred wheels, telescopic jib cranes, truck mounted strut-jib cranes and tower cranes.

### MOBILE CRANES:

In wide spread project sites, mobile cranes provide the best means for lifting and shifting of small to heavy loads. These cranes can move over level firm surfaces as well as on rough terrains.

Mobile cranes are of the following types:

(a) Crawler-mounted cranes: These cranes spread their dead load over larger area through their long tracks, and as such are useful while working in unprepared surfaces. The boom of these cranes comes in sections, which are joined by pin connections. The straight boom thus formed can lift loads over a radius of 30 to 40 metres. In order to overcome the ground obstruction to the inclined boom, a fly-jib (say, 18 metres in length) is attached to the top of the end boom. The fly-jib is generally inclined at 30 degrees offset from the main boom and it acts as its extension. The crawler jib crane can also be converted into a grabbing crane or dragline crane by fitting appropriate attachments.

(b) Self-propelled rubber-tyred wheels cranes: These cranes have greater mobility over hard surfaces and are in great demand for shifting and transporting light loads over short distances, and for off-loading of medium to heavy loads. Self-propelled cranes can be broadly divided into three categories.



\* Strut-jib cranes for shifting small loads at a distance, where ground obstruction restricts the utility of the crane.

\* Cantilever-jib crane provides greater clearance under the jib for heavy and bulky loads.

\* Telescopic-jib crane provides flexibility in adjusting distances and heights of lifts. It has greater mobility on roads than other self-propelled cranes.

\* TRUCK MOUNTED CRANES: These cranes are used for lifting medium to heavy loads over high and wide reaches, such as placing precast concrete slab panels in a high rise structures.

\* Calculation of truck production:

Example- Construction of a military helipad at an altitude of 2400m involves 80,000 m<sup>3</sup> (loose) of area excavation in soft soil. This task is to be completed in 200 working hours. The company entrusted with the execution of the task has two dozers each with an output of 220 m<sup>3</sup>/h under job conditions. It also holds wheel loaders and 22m<sup>3</sup> dump trucks. One loader can load in trucks about 120m<sup>3</sup> of excavated soil per hour. The dump truck cycle time for disposal of excavated materials is 35 mins. This includes 7mins of loading time by a loader team consisting of 2 loaders. Estimate the output of front-end loader for loading excavated soil heap into dump trucks & determine approximately the number of dozers, loaders and dumpers required to complete the task on time.

Solution:-  $\text{DOZERS required} = \frac{\text{Excavation quantity}}{\text{output/h} \times \text{working hour}} = \frac{80,000}{220 \times 200} = 2$

$$\text{Loaders required} = \frac{\text{Excavation/h by dozers}}{\text{Loader output/h}} = \frac{\text{No. of dozers} \times \text{dozer output/h}}{\text{Loader output/h}}$$
$$= \frac{2 \times 220}{120} = 4 = 2 \text{ loader teams, each team consists of}$$

$$\text{Dumpers required for one loading team} = 1 + \frac{\text{Dumper cycle time} \times \text{2 dozers}}{\text{loading time}}$$

For each loading team of 2 front end loaders

$$\text{Dumpers} = 1 + \frac{35}{7} = 1 + 5 = 6$$

$$\text{Total dumpers required for 2 loading teams} \Rightarrow 2 \times 6 = 12.$$

## \* Compaction Equipment:

The compacting process increases the density of soil by reducing air void space. Consolidation on the other hand, increases soil density by reducing water voids. Consolidation is a long-term process spread over years, whereas compaction can be achieved in a few hours. Compaction improves bearing strength, permeability and compressibility. Compacting equipment combine their static weight with tamping, vibration, impact and kneading action to produce the desired compacting effort. Compaction equipment requirement varies with soil characteristics and compacting effort.

The compacting equipment can be broadly classified into

- \* Tamping foot rollers,
- \* Pneumatic tyred rollers,
- \* Vibratory rollers
- \* Impactors
- \* Plate vibrators
- \* Smooth steel-wheel rollers.

### Segmented pads and Tamping Rollers:

A tamping roller consists of one (or) more hollow steel cylindrical drums with rows of steel studs like sheep's feet mounted on it. As the roller is towed with a crawler tractor, these studs punch into the soil and compact it by tamping and kneading action. Generally, the compaction gets carried out to a depth of 150mm. The cylinder drum can also be filled with water (or) sand to add extra weight while compacting.

The compaction depends upon the nature of the soil and the roller passes are continued till the feet do not dig into the surface being compacted. There are many varieties of tamping foot



rollers. These include sheep's foot rollers for compacting very cohesive soils, tamping foot rollers for compacting soil with low to medium cohesiveness, and grid or mesh segmented rollers for compacting granular soils, specially gravels. In general, the depth of compaction achieved in layers with the sheep's foot roller is nearly equal to the depth of the stud. Tamping foot rollers are rated in terms of static load (or) foot pressure (termed the ground contact pressure) on the soil surface unit area.

### \* SMOOTH WHEELED ROLLERS

These rollers have one or more smooth ~~hard~~ steel wheels, and are generally self-propelled. The self-propelled tandem and 3-wheel-d rollers are used for finishing compaction of layers up to 150mm of sand, gravel and water bound macadam used in base courses. Smooth wheeled rollers are employed for compacting bituminous materials specially the top layers in road surfacing operation. Smooth wheeled rollers are classified either by type or weight or both. Various types of rollers include 3-wheel two axles, 2-wheel tandem and 3-wheel tandem. The weight of the rollers can also be increased by ballasting with water, sand, or pig iron. Rollers are designated in terms of static weight and ballasted weight i.e. 15/20 tons means that the static weight of the roller is 15 tons and the maximum weight when ballasted is 20 tons. In order to indicate the pressure exerted, these rollers are also designated by specifying the minimum weight per linear width of roller i.e. 60 kg/cm width.

### \* PNEUMATIC ROLLERS;

Pneumatic rollers are available in light, medium and heavy weights. They compact soil by a kneading action. The weight of the equipment can be nearly doubled with ballasting using water, sand or pig iron, and the ground pressure can be maintained as desired by controlling the weight of the ballast, the number of the wheels, the width of the tyres and the tyre pressure. The pneumatic tyred rollers are rated in terms of tyre pressure (ground contact pressure) per unit area. It may be noted that the load on the tyres determines the depth to which compaction is possible, whereas both the tyre pressure and the tyre load are important for achieving compaction near the surface.



## Load Requirements for Compaction at Different Depths

| Passes | JOB CHARACTERISTICS            | MAX. DEPTH of LAYER (in mm) | Load Desired (in tons) |
|--------|--------------------------------|-----------------------------|------------------------|
| 4 to 8 | Compaction of loamy Sand       | 300 mm                      | 1.5 to 1.7             |
|        |                                | 500 mm                      | 2.0 to 2.5             |
|        |                                | 700 mm                      | 4.0 to 4.5             |
| 4 to 6 | Compacting Bituminous material | 80 mm                       | 1.5                    |
|        |                                | 130 mm                      | 2.5                    |
|        |                                | 200 mm                      | 4.0                    |

### \* VIBRATORY ROLLERS AND COMPACTORS

Vibration improve compaction and save time when compared with the static weight method of compaction. vibrations set the rim roller in oscillation, and there in turn transmit vibrations to the soil. vibrations are induced by installing a rotating eccentric weight inside the roller drum. vibratory rollers combine the static weight with dynamic forces. Maximum compacting effort is produced when the resonance frequency of the roller and soil coincide.

Generally, the rating for the vibratory compactor is stated as total applied force' expressed in tons and it is the numerical sum of the dynamic forces plus static weight. The vibrating frequency is specified as cycles/minute, vibration frequencies range from 1400 to 3000 cycles per minute. Further, a slow displacements speed of say 2.5 to 4 km/h produces a better effect" than speedier movement.

Vibratory compactors are of various types and sizes. There include smooth, drum vibratory rollers and tamping foot vibratory rollers. There are widely used for compacting non-cohesive soils.

## \* MANUALLY OPERATED PLATE AND IMPACT COMPACTORS!

These are used for compaction of small stretches like base and trenches in a building foundation work, and are operated manually. In plate compactors, vibrations are provided by installing two eccentric weights rotating in opposite directions around the centre of gravity of plate. plate compactors are more effective on granular materials, whereas impact compactors are preferred for cohesive materials. The compacting factor effort in the impact (or tamping) compactor is delivered by raising a heavy weight and then dropping it on the surface of the soil. These compactors are mostly hand operated. However, track-mounted cranes can also be improvised to provide a free fall hammer effect on the soil surfaces.

## \* Production output of Roller compactors:

The nature of soil dictates the type of compacting equipment required, and the dry density, which can be achieved. After the compacting equipment is selected, its average output can be calculated as under:

$$\text{Compaction in } m^3/\text{hr} = \frac{WSTEC}{P}$$

W = Width compacted per pass in meters (M)

S = Compactor speed in M/h; T = Thickness of compacted layer

E = Job efficiency factor; C = Compacting factor

P = Number of passes required (varies from 4 to 6)

In the absence of actual data, the compacting factor can be assumed

|               | Compacted volume | Loose volume | Inplace volume | Inplace Dry density |
|---------------|------------------|--------------|----------------|---------------------|
| Common earth  | 1.0              | 1.41         | 1.18           | 1.8                 |
| Sand          | 1.0              | 1.21         | 1.18           | 1.7                 |
| clay          | 1.0              | 1.48         | 1.11           | 1.9                 |
| Gravel        | 1.0              | 1.17         | 1.11           | 2.0                 |
| crushed stone | 1.0              | 1.30         | 0.75           | 2.2                 |

(Water requirement in litres per hour = weight of loose soil to be compacted per hour in kg x (Optimum moisture content - Natural moisture content))



HOISTING EQUIPMENTS\* HOISTS:

Hoists are a means of transporting materials or passengers vertically by means of a moving level platform. Materials hoists come in basically two forms - static and mobile models. The static version consists of a mast or tower with the lift platform either cantilevered from the small section mast or centrally suspended with guides on either side within an enclosing tower. Mobile hoists usually do not need tying to the structure unless extension pieces are fitted, in which case they are treated as cantilever hoists.

Passenger hoists, like the materials hoists can be driven by petrol, diesel, or electric motor and can be of a cantilever or enclosed variety. The cantilever type consists of one or two passenger hoist cages operating on one side or both sides of the cantilever tower; the alternative form consists of a passenger hoist cage operating within an enclosing tower. Tying-back requirements are similar to those needed for material hoist.

\* CRANES:

It consists of a rotating structure for lifting and lowering horizontally on rubber tires (or) crawler treads.

(or)

A crane is a device used for hoisting and placing materials and machinery. It is used to facilitate handling of materials such as formwork, reinforcement, pipes and structural steel items. The use of cranes has greatly increased in the construction industry due mainly to the need to raise the large and heavy prefabricated components often used in modern structures. Cranes are available in different ranges and the choice of the crane is dependent on factors such as the weight of the materials and machinery to be lifted, the overall dimension, the distance to which they are to be placed, and the prevailing site condition.



\* Construction cranes can be broadly classified under two major categories.

(1) Tower cranes (2) mobile cranes

(1) Tower crane:

In appearance most of the tower cranes look alike, but not of same type. Various types of tower cranes are available in the market and it is important to choose the right tower crane for a project.

The tower cranes offer several advantages over conventional cranes and it is required to be familiar with the different features of the tower crane. The manufacturer's catalogue offers useful advice such as lifting capacities at different radii. Tower cranes are available in different types, sizes and capacities. The lifting capacities is one of the important selection parameters besides length of reach (radius), maximum hook height above ground, and crane positioning.

Tower cranes have distinct advantages over conventional lattice boom crawlers or truck cranes because the boom or jib looms high above the work site. The tower crane's jib can place its load anywhere within the radius of operation without interfering with the structure over which it swings. In addition, the operator can either be on crane or control the crane remotely using instrumentation located on the building structure, while enjoying an excellent view of the load and its surroundings at all times.

The use of tower crane has become synonymous with medium-to high rise construction, be it for buildings or for bridges, dams, cooling towers, etc. Tower cranes can be fixed or can be mounted on rails. In the latter case, it is referred to as travelling tower crane. Sites with multiple tower cranes in operation are very common these days, especially for fast-track construction projects.

Tower cranes can be classified into top-showering tower cranes and bottom-showering tower cranes. The main differences are in the manner in which they are erected and dismantled, and in the maximum lifting height.

### \* TOP scheuing tower cranes:

It require a longer duration to erect and dismantle, but they can be erected virtually upto any height. These cranes are suitable for medium- to high-rise construction projects where they are needed for longer durations. The main parts of a typical top scheuing crane are - undercarriage, mast, operator's cabin, scheuing ring jib and counterjib. These cranes are usually of stationary type, resting on the concrete or structural steel foundations. In the travelling tower crane, modular concrete blocks are used in the base to provide stability. The crane travels on heavy wheeled bogies mounted on a wide-gauge rail track. The travelling tower crane provides better site coverage for additional stability, counter-weights in the form of modular concrete blocks are also provided in the counterjib of the crane.

Top-scheuing tower cranes have a mast (also called tower) with modular, lattice-type sections. The mast is erected with the help of another lifting device. The crane rises in height by addition of sections one by one. Tower cranes also have provision of telescopic climbing frame through which new sections are inserted and height of the crane is raised. scheuing ring provides the rotating mechanism of the crane and is located at the top of the mast just below the boom. In the top-scheuing tower crane, only the jib, tower top and operator's cabin rotate.

### \* Bottom-scheuing tower cranes:

It have height limitations although they can be erected and dismantled very quickly - the reason they are known to be self-erecting and fast-erecting. These are suitable for low-rise construction and for short-term assignments. Bottom-scheuing tower cranes also consist of undercarriage, scheuing ring, scheuing platform, mast and jib. It has a scheuing ring located near the base and both the mast and the jib rotate relative to the base. Since virtually the entire crane rotates, anchoring the crane with some fixed support is not possible. This is the reason for the shorter height of a bottom-scheuing crane relative to a top-scheuing crane.



## \* MOBILE CRANE

The mobile cranes have their own prime movers and, thus, are capable of moving freely on the project sites. Mobile cranes come in a wide variety of designs and capacities. The cranes typically consist of an undercarriage, an engine to propel the movement, a boom at an inclination, and an operator's cabin.

The boom could be either a lattice-type steel boom or a telescopic-type boom. The lattice boom has the advantage of simplicity in design and, consequently, lower cost. In order to extend or shorten the length of the lattice boom, the lifting operation is stopped and the extension pieces (also called the fly jibs) are added or removed. The telescopic boom has the advantage of having a boom that can be adjusted in length even during the lifting operation, which makes it faster when compared to lattice boom structure.

Mobile cranes can be either crawler-mounted or wheel-mounted depending on the arrangement of the undercarriage. Also, in contrast to tower cranes, mobile cranes can be used for purposes other than lifting such as excavation, pile driving and demolition, if fitted with suitable attachments.

Mobile cranes are characterized by the maximum lifting capacities. The lifting capacities vary at different radii and inclinations. In all types of cranes, the shorter the lifting radius, the greater will be the lifting capacity. The small-capacity machines have a fixed boom or jib length, whereas the high capacity cranes can have a sectional lattice boom or a telescopic boom to obtain various radii and lifting capacities. The mobile cranes are known for ~~there~~ their heavy load-lifting capacity and even a smaller mobile crane can have lifting capacities equal to or more than a tower crane.

Mobile cranes can be classified into four major categories.

- (1) Truck crane.
- (2) Crawler crane.
- (3) Rough terrain crane.
- (4) All terrain crane.



## \* TRUCK CRANES ;

The term 'truck crane' comes from the fact that the entire superstructure of the crane consisting of boom, engine, counter weight and operator's cabin is mounted on a special truck. Truck cranes are suitable for short-term lifting assignments only and should not be considered if the lifting assignments extends for longer duration. The booms in these types of cranes could be either lattice type or of telescopic type. Telescopic boom cranes are very popular because of the short time period required to prepare the crane for use upon arrival on site, making them ideally suitable for short hire periods. Truck cranes can travel with ease on rough terrain as well as on public roads. The cranes can travel between sites at speeds of up to 48 km/h, which makes them very mobile, but to be fully efficient they need a firm and level surface from which to operate.

## \* CRAWLER CRANES ;

It have better manoeuvrability and can be quickly relocated at different locations on a project site. However, for shifting to another project site, these cranes require a truck or a trailer. The inability to be shifted from one site to another on its own is one of the main disadvantages of the crawler crane. Nevertheless, these cranes can work in difficult ground conditions. The cranes normally have lattice boom but are also available with telescopic boom option.

## \* Rough-terrain cranes ;

It have high mobility and can work best if combined with the operation of a tower crane. These cranes are very good in rough terrain conditions and where frequent relocation of cranes is needed. They are available with both the lattice - and telescopic - type booms. The rough-terrain cranes can manage grades even up to 35°.

## \* ALL-TERRAIN CRANES:

As the name suggests, all-terrain cranes can manoeuvre through rough terrain as well as public roads with ease. These cranes are technologically the most advanced of all the mobile cranes. They come in both lattice-type and telescopic-type boom options.

## \* BULLDOZERS:

The bulldozer is a versatile machine. It can be used for moving earth over distances upto 100m, clearing and grubbing sites, stripping top unwanted soil, excavating to a shallow depth say up to 200mm at a time, pushing scrapers, spreading soil for levelling areas, ripping base soft rock, and maintaining roads. Bulldozers normally are track mounted, however there are four-wheeled dozers with large-powered engine. The wheel dozers exert higher bearing pressure as compared to track-dozers.

Dozers excavate and push earth with the help of a stiff welded steel blade fitted in front and controlled by two hydraulic cylinders. Commonly used blades are of three types. The straight S-blade is used for forward pushing of earth. U-blades have large capacity, and are used for pushing loose materials. Angle A-blades are used for pushing soil to one side rather than hauling it forward as is required in hill road formation cutting. A dozer can also be fitted with a backhoe attachment for ripping hard soil and rock, and a winch for uprooting trees, skidding boulders and heavy materials.

Ideal output for dozing soft soil depends upon the engine power, straight blade capacity and dozing distance.

## \* SCRAPER:

It is the equipment commonly used for scraping, loading, hauling and discharging including spreading large quantities of earth over long distances; say around three km. It can scrape soils in layers of 15cm to 30cm in depth. Basically, a scraper has a soil container (or bowl) mounted on two wheels. It digs into the earth after the forward



portion of the container is lowered, and it collects the earth as the scraper moves forward. unloading and spreading takes place in controlled layers ~~keeps the earth as the scraper moves forward~~ layers in the discharge area with the aid of a tractor plate while the unit keeps on moving. Scrapers come in many sizes varying from  $8\text{m}^3$  to  $50\text{m}^3$ . There are two main categories of scrapers i.e. towed scrapers and motorized scrapers.

### \* Towed scrapers:

These are pulled by a tractor or a bulldozer capable of 300 HP or more. Although the loading cycle may take hardly two (or) three minutes, its travelling speed is slow. Its main advantage over the motorized scraper is that it can operate in small areas and can scrape in heavy soil areas. Towed scrapers are best suited for medium distances up to 400m. Towed scrapers capacity ranges from  $8\text{m}^3$  to  $30\text{m}^3$ .

### \* Motorized scrapers:

Several types of motorized scrapers with heaped capacity ranging from  $15\text{m}^3$  to  $50\text{m}^3$  are available to suit varying job requirements. These include single engine scraper, double engine scraper and elevating scraper.

(a) Single engine scraper requires a pusher bulldozer to provide the necessary tractive force. Generally one medium-sized crawler tractor is sufficient to serve four to five scrapers.

$$\text{scrapers per pusher} = \frac{\text{Cycle time of each scraper}}{\text{cycle time of pusher.}}$$



(b) Double-engine scrapers are fitted with two engines, one in the front and the other in the rear axle. For scrapers having capacity  $35 \text{ m}^3$  and above, two engines are preferred instead of one very large equivalent engine. Although the engine in the rear provides a four wheel drive, double-engine scrapers do require a pusher specially in hard soil excavations. In the push-pull method, two double engine scrapers are used to mutually load each other in turn, without the aid of a pushers.

(c) Elevating scrapers are fitted with an elevating mechanism for self-loading. Due to their heavy weight, they are at a disadvantage over long hauls.

### \* GRADERS:

These are used to grade earthen road formations and embankments to their finished shape within specified limits by trimming the surface. The graders can also be used for forming ditches, mixing and spreading soils, backfilling and scarifying ground.

The motor grader is the equipment mostly used for grading and finishing at large areas. Motor graders generally have engines up to 300 HP and the latest models are provided with hydraulically controlled attachments. These attachments include an excavation blade similar to the bulldozer, scarifier, ripper and backhoe. The blade of the motor grader has replaceable cutting edges. These blades come in flat, curved and serrated styles. Motor graders are fitted with articulated frames for increasing manoeuvrability. Motor graders are now available with automatic grade controls for achieving the desired grading. Grading distance of 500 meters and above give optimum output. For shorter distances, task efficiency gets reduced:

|                    |     |     |     |     |
|--------------------|-----|-----|-----|-----|
| Distance in meters | 50  | 100 | 200 | 500 |
| Task efficiency    | 0.4 | 0.6 | 0.8 | 1.0 |

Graders' optimum output for finishing is measured in  $M^2/\text{hour}$  on the area basis or  $\text{km}/\text{hour}$  on a linear basis!

$$\text{OUTPUT in } M^2/\text{hour} = \frac{W \cdot S \cdot E}{P}$$

$W$  = Width graded per pass,  $S$  = Avg. speed in  $m/h$

$E$  = Job efficiency factor,  $P$  = Number of passes (4 to 6 generally)

and the grader speed for various operations can be taken under:

| Operation                     | Speed $\text{km}/h$ |
|-------------------------------|---------------------|
| Rough grading                 | $4 \approx 10$      |
| Finishing (Including grading) | $6 \approx 15$      |
| Mixing                        | $15 \approx 30$     |
| Spreading                     | $6 \approx 15$      |
| Self transporting             | $10 \approx 40$     |

EXAMPLE: Calculate the time required to grade and finish 30km of road formation with width equal to thrice the width of the motor grader, using six passes of the motor grader with speed for each of the successive two passes as  $6 \text{ km}/h$ ,  $8 \text{ km}/h$  and  $10 \text{ km}/h$  respectively. Assume machine efficiency based on operator's skill, machine characteristics and working conditions as 75%

$$\text{Average} = \frac{2 \times 6 + 2 \times 8 + 2 \times 10}{6} = 8 \text{ km}/h$$

Area to be graded per hour

$$= \frac{\text{Width graded per pass} \times \text{Average speed} \times \text{Machine efficiency}}{\text{Number of passes}}$$

$$= \frac{W \times 8 \times 1000 \times 0.75}{6}$$

Number of hours required to grade and finish 30km long and 3W

$$\text{wide area} = \frac{\text{Total area}}{\text{Area/hr}} = \frac{30 \times 1000 \times 3W}{[W \times 8 \times 1000] \times 0.75 + 6} = 90 \text{ hrs}$$

### \* DRAGLINE :-

It is a rope-operated boom fitted crane type machine. The bucket is thrown into the excavation area, and the cable-controlled hook is rotated, so that, the bucket gets filled by scraping the surface to be excavated. It is used for digging below the ground level specially, in loose soils or marshy and underwater areas with soft beds. The commonly used dragline can operate in a depth approximately up to  $\frac{1}{3}$  of its boom length for broad sweeping type excavated work. Its boom length varies from 21m to 36m and the struck bucket capacity extends from  $\frac{1}{2} \text{ Yd}^3 (0.38 \text{ m}^3)$  to  $4 \text{ Yd}^3 (3.06 \text{ m}^3)$

### \* CLAMSHELL (OR) GRAB :-

Like dragline, it is a rope-operated boom-fitted crane type machine having a grab (or) clamshell bucket. The grab bucket has interlocking teeth to penetrate loose soil whereas the clamshell bucket has no teeth. These buckets are dropped with their sides open like open jaws on the soil to be grabbed, and thereafter, these jaws are closed by rope machines prior to hauling. These machines are used primarily for deep confined excavations such as shafts, wells and spoil heaps removal. The depth of the excavation can be roughly taken as  $\frac{1}{3}$  of the boom length. The range of the size of the grab bucket and its length of boom are similar to those of the dragline.



## UNIT-V

### CONCRETING EQUIPMENTS

- \* Selection of concreting equipment can be complicated and difficult. The following factors are noteworthy:
  - Site characteristics such as boundary conditions, equipment manoeuvre, provision of temporary roads, noise limitations and other restrictions.
  - Equipment availability - local availability of equipments, whether the contractor owns that equipment.
  - Continuity of operation.
  - Effect of permanent work.
  - Weather conditions.
  - Temporary works.
  - Time restrictions.
  - Concrete specifications.

#### \* Concrete batching and mixing plant

Purpose: for weighing and mixing large quantity of concrete constituents.

Capacity:  $20 \text{ m}^3/\text{h}$  to  $250 \text{ m}^3/\text{h}$

It comes in different varieties such as stationary & mobile batching plants.

#### \* Concrete mixers

Purpose: For mixing small quantities of concrete constituents.

Capacity: Capacity could be up to 200 l/batch for small mixers, and between 200 and 750 l/batch for large mixers

comes in different varieties such as non-tilting drum type and tilting drum type.

## \* Concrete transit Mixers;

→ Purpose: For transporting concrete from batching plant.

→ Capacity:  $3\text{m}^3$  to  $9\text{m}^3$

→ Capacity also depends on the permissible axle load.

## \* Concrete pumps, static or portable;

→ Purpose: For horizontal and vertical transportation of large volumes of concrete in short duration.

→ Capacity:  $30\text{m}^3/\text{h}$  for ordinary construction; can be in excess of  $120\text{m}^3/\text{h}$  for specialized construction.

→ Direct acting pumps - an output of up to  $60\text{m}^3/\text{h}$  through  $220\text{mm}$  delivery pipes. Concrete can be easily pumped up to a distance of  $450\text{m}$  horizontally or  $50\text{m}$  vertically.

→ Squeeze pumps - an output of up to  $20\text{m}^3/\text{h}$  through  $75\text{mm}$  delivery pipes. Concrete can be easily pumped up to a distance of  $90\text{m}$  horizontally or  $30\text{m}$  vertically.

## \* CRUSHERS;

A crusher is a machine designed to reduce large rocks into smaller rocks, gravel, or rock dust.

Crushers may be used to reduce the size, or change the form, of waste materials so they can be more easily disposed of or recycled, or to reduce the size of a solid mix of raw materials (as in rock ore), so that pieces of different composition can be differentiated. Crushing is the process of transferring a force amplified by mechanical advantage through a material made of molecules that bond together more strongly, and resist deformation more, than those in the material being crushed do. Crushing devices hold material between two parallel or tangent solid surfaces, and apply sufficient force to bring the surfaces together to generate enough energy within the

material being crushed so that its molecules separate from (fracturing), or change alignment in relation to (deformation), each other. The earliest crushers were hand-held stones, where the weight of the stone provided a boost to muscle power, used against a stone anvil.

### \* JAW CRUSHER;

A jaw crusher uses compressive force for breaking of particle.

This mechanical pressure is achieved by the two jaws of the crusher of which one is fixed while the other reciprocates. A jaw or

toggle crusher consists of a set of vertical jaws, one jaw is kept stationary and is called a fixed jaw while the other jaw called a

swing jaw, moves back and forth relative to it, by a cam or pitman mechanism, acting like a class II lever or a nutcracker. The volume

or cavity between the two jaws is called the crushing chamber.

The movement of the swing jaw can be quite small, since complete crushing is not performed in one stroke. The inertia required to crush

the material is provided by a weighted flywheel that moves a shaft creating an eccentric motion that causes the closing of the gap.

Jaw crushers are heavy duty machines and hence need to be robustly constructed. The outer frame is generally made of cast iron

or steel. The jaws themselves are usually constructed from cast steel. They are fitted with replaceable liners which are made of manganese

steel, or Ni-hard (a Ni-Cr alloyed cast iron). Jaw crushers are usually constructed in sections to ease the process transportation if

they are to be taken underground for carrying out the operations.

Jaw crushers are classified on the basis of the position of the pivoting of the swing jaw.

→ Blake Crusher: The swing jaw is fixed at the upper position.

→ Dodge crusher: The swing jaw is fixed at the lower position.

→ Universal Crusher: The swing jaw is fixed at an intermediate position.



## \* GYRATORY CRUSHER:

It is similar in basic concept to a jaw crusher, consisting of a concave surface and a conical head; both surfaces are typically lined with manganese steel surfaces. The inner cone has a slight circular movement, but does not rotate, the movement is generated by an eccentric arrangement. As with the jaw crusher, material travels downward between the two surfaces being progressively crushed until it is small enough to fall out through the gap between the two surfaces. A gyratory crusher is one of the main types of primary crushers in a mine or ore processing plant. Gyratory crushers are designated in size either by the gape and mantle diameter or by the size of the receiving opening. Gyratory crushers can be used for primary or secondary crushing. The crushing action is caused by the closing of the gap between the mantle line (movable) mounted on the central vertical spindle and the concave liners (fixed) mounted on the main frame of the crusher. The gap is opened and closed by an eccentric on the bottom of the spindle that causes the central vertical spindle to gyrate. The vertical spindle is free to rotate around its own axis. The crusher illustrated is a short-shaft suspended spindle type, meaning that the main shaft ~~design~~ is suspended at the top and that the eccentric is mounted above the gear. The short-shaft design has superseded the long shaft design in which the eccentric is mounted below the gear.

## \* IMPACT CRUSHER:

- Impact force is used to crush material.
- Material will be crushed by the impact plate and rebound to the blow bar again after being crushed.
- The space between rotor and impact curtain can be adjusted in order to changing the crushing degree.

Processing capacity : 30 - 800 t/h

Applied material: limestone, granite, coal, slag, clay.

## \* EQUIPMENT SELECTION:

### EQUIPMENT SUITABILITY:

- Type of equipment considered suitable for the task.
- Make, models and sizes of special purpose, and general purpose equipment available that can handle the task.
- production capability, serviceability condition and delivery time of each equipment available.
- Equipment already owned by the contractor. usefulness of the suitable equipment available for other and future tasks.

### TASK CONSIDERATIONS:

- Nature of task and specifications.
- Daily or hourly forecast of planned production.
- Quantity of work and time allowed for completion.
- Distribution of work at site.
- Interference expected and interdependence with other operations.

### SITE CONSTRAINTS:

- Accessibility to location - Maneuverability at site.
- Working space restrictions.
- Altitude and weather conditions.
- Working season and working hours.
- Availability of local resources of manpower, materials & equipment.
- Availability of equipment hiring, repair and maintenance facilities, locally.
- Availability of fuel, oil and lubricants.

### MAINTAINABILITY:

- Ease of repair and maintenance.
- Vendor's after-sale service, repairs, spares and maintenance.
- Availability of spare parts.
- Standardization consideration.

## \* OPERATING RELIABILITY

- Manufacturer's reputation.
- Equipment components, engine-transmission, operator's cabin.
- Use of standard components.
- Warranties and guarantees.
- operator's acceptability, adaptability and training requirements.
- Structural design
- Preventive maintenance programme
- Safety features).

## \* ECONOMIC CONSIDERATIONS

- Owning costs.
- operating costs.
- Re-sale or residual value after use
- Replacement costs of existing equipment.

## \* COMMERCIAL CONSIDERATIONS

- Buy second-hand or new equipment
- Rent Equipment
- Hire-purchase equipment.
- purchase on lease.

## \* CONSOLIDATING AND FINISHING:

Consolidation aims at removing air voids in the concrete at the time of placing, consolidation is achieved with the help of concrete vibrators, which come in many sizes depending upon the nature of their vibrating application such as in narrow slits, columns, slabs, mass concreting, etc., ~~finishing~~

Finishing operations make use of screed vibrators, manual/power trowels, and tools necessary for ~~undertaking~~ undertaking various types of finishes such as exposed aggregate, broom, and textured pattern-shape finishes.



## \* PLACING CONCRETE:

At the delivery site the concrete transported by truck-mixers is hauled horizontally and/or vertically for final placing into the forms. Concrete pumps provide the most acceptable, easy and quick method of placing concreting. These are commonly used in the industrialized countries. Concrete pumps can be broadly divided into two categories, viz. truck-mounted mobile pumps and trailer-mounted stationary pumps. Truck-mounted mobile pumps have the ability to deliver concrete up to  $120 \text{ m}^3/\text{h}$  at a height above 40 metres. But it creates handling and logistic difficulties. Usually mobile concrete pumps operate in the range of  $35-45 \text{ m}^3/\text{h}$  or even less. The pumping distance and price of the pump depends upon the boom length of the pump. For planning purposes, the vertical distances at which a concrete pump can deliver concrete with its boom can be taken as  $2/3$  of the boom length with remaining boom length being used for placing concrete horizontally. The mobile concrete pumps are frequently moved from place to place. They can also be used in the stationary mode of delivering concrete, horizontally or vertically up to designed distances, by fixing and suitably anchoring extension pipes. The stationary concrete pumps are mounted on trailers and are moved occasionally. These are positioned in the vicinity of the place where concrete is to be delivered by pumping concrete vertically or horizontally. The pump is connected to the delivery site by a pipeline through which the concrete is pumped. Pumping distance depends upon the capacity of the pump, horizontally and vertical pumping distance and the nature of bends in the pipeline. These details can be found in the manual of the concrete pump.

## \* SCREENING OF AGGREGATES!

Aggregates are inert materials which are mixed with binding materials such as cement or lime for manufacturing of mortar or concrete. Aggregates are used as filler in mortar and concrete and also to reduce their cost.

Screening is the separation of material into 2-6 different sized products. The material is separated by passing it through a vibrating 'screen box' which has a number of different sized screens, or meshes, which the material falls through like a sieve.

Depending on the size of their particles aggregates are classified as:

as: (1) Fine aggregate (2) Coarse aggregate.

1) Fine aggregate: Aggregates whose particles pass through

4.75mm IS sieve are termed as fine aggregates. Most commonly used fine aggregates are sand (pit or quarry sand, river sand and sea sand) and crushed stone in powdered form, however some times ash or cinder are also used.

2) Coarse aggregates: Aggregates whose particles do not pass through 4.75mm IS are termed as coarse aggregates. Most commonly used coarse aggregates are crushed stone, gravel; broken pieces of burnt bricks, etc,

\* CONSTRUCTION METHODS;

Earth Work: Earthworks are engineering works created through the moving and/or processing of massive quantities of soil (or) unformed rock. Earthwork is done to reconfigure the topography of a site to achieve the design levels.

Earthwork involves cutting and filling to achieve the required topography.

clearing & Grubbing;

- Removal of trees, shrubs, and other vegetation.
- Removing stumps and root mat at least 2' (600mm) below subgrade
- Less removal required for embankment height > 5'
- Topsoil striping
- Muck Excavation.

Prior to starting any earthwork;

- Verify location of underground utilities through "Miss Utility" or local "one-call" system.
  - check for utilities not included in one-call system
- - dig pits test pits to confirm actual locations.
- Note location of aerial utilities for equipment and truck clearances.
- confirm that all applicable permits and approvals have been secured.
- Install all required Erosion & Sediment Control devices.
- Review soil borings and other geotechnical information.
- Observe existing drainage patterns
- plan access and excavation patterns



- \* → Determine handling of spoils.
- verify original ground surfaces (compare against existing contours (or) cross sections shown on the plan)

### \* SUCCESSFUL EARTHWORK OPERATIONS:

- Control Surface and Subsurface water.
- Maintain optimum moisture range by drying, mixing or wetting
- Identify and monitor cut & fill quantities.
- Good Layout (horizontal & vertical control)
- Minimize handling - minimize stockpiling.
- Optimize haul lengths
- minimize cycle time
- Proper selection and sizing of excavators and haul units
- Alternate haul unit wheel paths
- Experienced personnel in the field.

### \* QUALITY CONTROL: (QC)

Quality control is defined as a set of activities (or) techniques whose purpose is to ensure that all quality requirements are being met. In order to achieve this purpose, processes are monitored and performance problems are solved. Thus, quality control describes those actions that provide the means to control and measure the characteristics of an item, process, or facility against the established requirements. Quality control is basically the responsibility of the production personnel. A typical quality control programme would consist of defining quality standard, defining procedures for the measurement of attainment of that standard, execution of the procedures to determine probable attainment or non-attainment of the standard, and the power to enforce and maintain the defined standard as measured according to the defined procedure.

\* In the context of construction, quality control is determined by the contractors or by the specialist consultants such as consulting engineers or testing laboratories. Construction quality control entails performing inspection, test, measurement and documentation necessary to check, verify and correct the quality of construction materials and methods. Primary objectives of construction quality control are to be produce a safe, reliable and durable structure so that the owner gets the best value of his investment.

The construction industry does not abide by a formal quality control programme as do the construction related industries. Quality control on some projects could be haphazard and inconsistent. Because of heterogeneity, it is impossible to employ a uniform approach to check quality standards of construction work. Three major quality control methods commonly used on construction projects are:

→ Inspection

→ Testing

→ Sampling

Techniques used vary from subjective evaluation to objective assessment of quality attained. The type adopted depends on the characteristics of construction activities or systems being examined and the degree of certainty desired. While all the methods may be feasible, not all of them are applicable on a particular activity. It is necessary that the methods to be used are as defined in the contract documents, to eliminate any confusion. Because of the nature of the construction work, absolute compliance with specifications is impractical. The objective of quality assurance examination is to determine the degree of compliance with contract quality standards. A realistic approach is to first establish a minimum quality standard that will be the basis of acceptance or rejection. Appropriate quality control methods can thereafter be used to judge if variations are within the acceptable tolerances. Best results are obtained if QC is consistent & the techniques used are appropriate.



## \* NEED FOR INSPECTION AND QUALITY CONTROL :

The objective of inspection and Quality control is to achieve sound construction work which results in structures of good quality at reasonable cost. Inspection and quality control are required on all construction projects to ensure that the work done is accordance with plans, specifications and good practice and to avoid defects. An entirely safe design may be completely ruined by careless execution. This can lead to defective work with possibility of failure of the structure. Careful inspection and quality control is, therefore, as important as the preliminary investigation and design. As it is very difficult and expensive to rectify a structure after it is constructed, it is necessary to inspect the structure during its various construction stages.

- Sampling, identification, examination and field testing of materials.
- Measurement and proportioning of construction materials;
- Examination of layout; formwork, foundations etc,
- Testing specimens in the laboratory;
- Observation of construction equipment and plant;
- preparation of records and reports.

In a construction project, quality control is one of the important functions of management. It is primarily required to satisfy the owner's stated needs and requirements. Quality control ensures that work proceeds in accordance with the specifications laid down and inspection is the tool through which it is practised.

## \* TESTING OF STRUCTURES

- NON-destructive tests
- Full scale load test
- Leak proof and dampness test.

## \* NON-DESTRUCTIVE TESTS :

- (a) Schmidt rebound hammer
- (b) Ultrasonic pulse velocity
- (c) Gamma radiography
- (d) Electromagnetic cover meter
- (e) Elastostonic test
- (f) Core test



## \* SAFETY ENGINEERING

### IMPORTANCE OF SAFETY:

Safety in construction is a prime requisite but it often gets neglected on work sites. With the advancement in construction technology, the need for proper attention to safety aspects has become essential for human, economic and other considerations.

The wide range of construction and building activities involving complex techniques have led to many new problems of safety. Proper steps should be taken to improve safety on construction sites so that the loss of life and limb, maiming and damage resulting from avoidable accidents is prevented. Promotion of safety measures at site will result in a better work environment, higher productivity and greater contentment among workers.

Most of the accidents in the construction industry happen due to lack of proper education and training in regard to safety measures and also because of negligence and ignorance on the part of either the worker or management or both.

### \* PRINCIPLES OF SAFETY:

Dan Petersen (1989) mentions ten basic principles of safety:

- An unsafe act, an unsafe condition, and an accident are all symptoms of something wrong in the management system.
- We can predict that certain sets of circumstances will produce severe injuries. These circumstances can be identified & controlled.
- Safety should be managed like any other company function. Management should direct the safety effort by setting achievable goals and by planning, organizing and controlling to achieve them.

- The key to effective line-safety performance is management procedures that fix accountability.
- The function of safety is to locate and define the operational errors that allow accidents to occur. This function can be carried out in two ways:
  - \* By asking why accidents happen - searching for their root causes.
  - \* By asking whether certain known effective controls are being utilized.
- The causes of unsafe behaviour can be identified and classified. Some of the classifications are - overload (the improper matching of a person's capacity with the load); traps; and the workers' decision to error. Each cause is one that can be controlled.
- In most cases, unsafe behaviour is normal human behaviour; it is the result of normal people reacting to their environment. Management's job is to change the environment that leads to unsafe behaviour.
- There are three major subsystems that must be dealt with in building an effective safety system; (1) The physical (2) The managerial (3) The behavioural.
- The safety system should fit the culture of the organization.
- There is no one right way to achieve safety in an organization; however, for a safety system to be effective, it must meet certain criteria: The system must:
  - \* Force supervisory performance.
  - \* Involve middle management.
  - \* Have top management visibly showing their commitment.
  - \* Have employee participation.
  - \* Be flexible.
  - \* Be perceived as positive.

## \* ROLES OF SAFETY PERSONNEL:

The various duties of a Safety officer as stipulated in the Law will help clarify the confusion & these are mentioned below:

- TO advise the building workers for effective control of injuries.
- TO advise on safety aspects to carry out detailed safety studies.
- TO check and evaluate effectiveness of action.
- TO advise on purchasing and ensuring quality of personal protective equipment.
- TO carry out safety inspections of building.
- TO investigate the cases of occupational disease.
- TO advise on maintenance of records related to accidents, etc.
- TO promote the working of the Safety committee.
- TO organize campaigns, contests and other such activities.
- TO design and conduct training and educational programme.
- TO frame ~~and conduct training~~ safe rules and safe working practices).
- TO supervise and guide safety precautions.

## \* CAUSES OF ACCIDENTS:

Accidents can occur at construction sites on account of:

- LACK OF planning and organization.
- Defects in technical planning.
- Fixing unsuitable time limits and targets too difficult to achieve.



- Assignment of work to incompetent contractors.
- Insufficient ~~at work~~ (or) defective supervision.
- Lack of cooperation among different crafts.
- Inadequate preparation for work.
- Inadequate instructions concerning work.
- Employment of unskilled or insufficiently trained workers.
- Inadequate supervision of work.
- Worker's irresponsible behaviour, unauthorized action & carelessness.
- Faulty construction such as collapse of walls & other building parts.
- Lack of necessary equipment & use of unsuitable equipment.
- Structural or other defects in equipment being used.
- Lack of safety devices or measures.
- Unsuitable building materials and
- Defective processing of building materials.
- Collapse of stacks, masses of earth, etc.
- Collapse ~~at~~ and overturning of ladders, scaffolds, stairs, beams, etc.
- Fall of objects, tools, pieces of work, etc.
- Fall of persons from ladders, stairs, roofs, scaffolds, buildings, through some openings, etc.

### \* SAFETY MEASURES:

Prevention of accidents is a major aim of construction management, both for human and financial considerations. Whatever the nature of construction projects, accidents are likely to occur causing physical injury, casualties and loss of money. In order to prevent accidents at construction sites, certain safety measures need to be taken in the following major activities prone to risks of accidents.

- Excavation
- Drilling and Blasting
- Hot Bituminous works
- Scaffolding, Ladders, Form-work & other Equipment
- Fabrication and Erection
- Storage
- Demolition.

### \* Safety Measures for Excavation

- (i) In all works, an experienced and Competent foreman or Supervisor, should look after the excavation work. He should have authority to enforce safety rules and prevent the use of defective/unsafe appliances.
- (ii) Before doing the excavation work, a complete knowledge of underground structures (Such as Sewers, water pipelines, gas mains etc) is essential and proper precautions should be taken to prevent accident to the workmen engaged in excavation work.
- (iii) Safety helmets should be worn by all persons entering a trench where hazards from falling stones, timber or other materials exist.
- (iv) Whenever workmen have to excavate in trenches, in soil, soft or fissured rock, or hard soil exceeding 2m in depth, the trenches should be securely shored and timbered.
- (v) Sheathing should be placed against the side of the trench so that the length of each piece of sheathing is vertical. Where the trench is excavated in loose or soft soil, each piece of sheathing should be driven into the bottom of the trench so as to be firmly held in place.
- (vi) Excavated material should be kept away from the edge of the trench in order to provide a clear berm width of not less than one third the final depth of excavation. However, in special cases where disposal area is limited, the minimum berm width should not be less than 1m.



(VII) Heavy equipment, such as excavating machinery, trucks, dumpers etc., should be kept away from the excavated sites at a distance not less than the depth of the trench or at least 6m for trenches deeper than 6m.

(VIII) At places where public is likely to trespass, fences or barricades should be erected to avoid accidents. At night, excavated areas should be adequately lighted.

### \* Safety measures for drilling and blasting;

- (i) To transport small quantities of explosives (approx 5 kg) specially designed insulated containers may be used which are made of finished wood not less than 5cm thick or plastic not less than 6mm thick. The container should be water proof and free from any metal parts (such as nails, screws etc.)
- (ii) vehicles to be used for transporting explosives should be in good working condition with tight wooden or non-sparking metal floor and sides.
- (iii) Smoking is strictly prohibited at places where explosives are stored.
- (iv) Explosives should be stored only in a magazine which is clean, dry, well ventilated, reasonably cool, bullet and fire resistant.
- (v) Explosives and fuse lighters should not be stored in a damp or wet place or near oil, gasoline or steam pipes, or other sources of heat.
- (vi) Leaves, grass or debris of any kind should not be allowed to accumulate within 8m of the magazine.
- (vii) Any package containing explosives should not be dragged, dropped or handled roughly and these packages should be opened only at a safe distance from the packages of explosive in bulk storage.
- (viii) No person should attempt to uncoil the wires and open the bare leading wires of the electric blasting caps (detonators) during dust storms.



## \* Safety Measures for Hot Bituminous Works:

- (i) on all major works, an experienced foreman or supervisor should be placed in charge of the work who should guard against the use of defective/unsafe appliances, equipment and tools and should keep stock of fire extinguishing equipment and first aid kit etc,
- (ii) Workers engaged on jobs involving handling of hot bitumen should use protective wares such as boots, gloves, goggles and helmets.
- (iii) When heating and handling of hot bituminous materials is to be done in the open, sufficient stocks of clean dry sand (or) loose earth should be kept ready at the work site to cope with any resultant fire. When such materials are not available, arrangement must be made for adequate supply of water to extinguish the fire.
- (iv) Bitumen plants should be provided with safe means of access: working platforms should be provided with hand rails, and pulleys, belts and drive mechanisms should all be protected by suitable guards.
- (v) Compressors, electrical installations and other equipment such as elevators and conveyors should be adequately protected from weather, mechanical damage and dust particles.
- (vi) When bitumen plants are working on a public road, an adequate traffic control system must be established.

## \* Safety Measures for Scaffolding, Ladders, Forwork and other Equipment

- (i) Every scaffold should be securely supported or suspended and properly strutted or braced to ensure stability.
- (ii) All scaffolds and working platforms should be securely fastened to the building or structure.

(iii) If scaffolds are to be used to a great extent for long periods of time, a regular plank stairway, wide enough to allow two people to pass, should be erected with handrails on both sides.

(iv) When work is being performed above a scaffold platform, a protective overhead covering should be provided for the men working on the scaffolds. The protection should not be more than 3m above the scaffold platform and should be made of planks.

(v) For wooden ladders, no rung should be fixed to the stringer with nails, spikes or other similar fixings. In case of bamboo ladders, rungs may be fixed to the rails with spikes of appropriate design and strength.

(vi) Ladders employed in heavier trades should not exceed 6m in length. For lighter trades, ladders should not exceed 8m in length.

(vii) During dismantling of scaffolds, necessary precautions should be taken to prevent injury to persons due to fall of loose materials, bracings and other parts of scaffolds.

(viii) Care should be taken to see that no un-insulated electric wires exist within 3 metres of the working platforms, gangway etc. of a scaffold.

(ix) The supporting ballies for formwork should be checked for each individual member. The ballies should be properly braced. Many accidents occur due to negligence on this account.

(x) All operators and supervisors of machines should be thoroughly trained in operating the machines and equipment. All persons handling construction equipment should be completely acquainted with the safety aspects of machines and their operation.

(xi) Safety in terms of both main and auxiliary equipment should be considered at all construction sites. Unauthorised persons should not be allowed to handle or operate any equipment. Ropes guys and connections should be thoroughly checked before use.



## \* Safety in fabrication and Erection!

- (i) All equipment such as gas cutting and welding sets, drills, power hacksaws, grinders etc, should be checked periodically to ensure their safe working.
- (ii) Moving parts of all equipment should be provided with safety guards.
- (iii) Rubber pipe-lines for oxygen and acetylene gas should be regularly checked for leakage and damage. Leakage of gas from regulators, pipe-lines or connections with the gas torch should be rectified immediately.
- (iv) Workers engaged in gas cutting and welding operations should wear suitable gloves and aprons and use proper welding screens.
- (v) Power cables for all equipment should be properly insulated and protected from damage and cuts.
- (vi) Danger signs should be prominently displayed on all poles of overhead electric lines/conductors used at site.
- (vii) Cut pieces and scrap should be stored at an appropriate place to avoid accidents.
- (viii) All lifting tools and tackles such as wire ropes, U-clamps, shackles, chainpulley, blocks hooks etc, should be checked thoroughly before undertaking erection work.
- (ix) All erection equipment such as cranes, derricks, hoists etc, should be thoroughly checked before use.
- (x) Workers engaged in erection work should wear helmets and use safety belts to avoid accidents.

## \* Safety in Storage!

- (i) Timber including sleepers, runners, scantlings, ballies, plywood etc, should be stored separately in neat stacks. Adequate space should be left in between the stacks to avoid fire hazard. Smoking and open fires should be prohibited in timber yards and stores.



- (ii) Petroleum products should be separately stored, smoking and open fires should be strictly prohibited where these products are stored. Only essentially required quantities of such products should be stored at site.
- (iii) Adequate fire fighting arrangements should be provided at site particularly in areas where petroleum products and timber are stored.
- (iv) Explosives must be stored in proper magazines and the prescribed safety measures for handling and storage of explosives should be observed.

### \* Safety Measures for Demolition:

- (i) on every demolition work, danger signs should be provided all around the structure and doors giving access to the structure. Barricades should be erected around the structure and at least two exits must be provided for the escape of workmen during any emergency.
- (ii) During night time, red lights should be placed around the barricades and entry of unauthorised persons restricted.
- (iii) At the time of demolition work, workers should wear all safety appliances such as helmets, goggles, gloves etc.
- (iv) In case any danger is anticipated to the adjoining structure during the process of demolition, the same should be got vacated to avoid any danger to human life.
- (v) The process of demolition may weaken the side walls of an adjoining structure and to prevent possible damage, these walls should be supported until permanent protection is provided.
- (vi) The power on all electrical services lines must be shut off and all such lines disconnected before the demolition work is started.
- (vii) All gas, water, steam and other service lines must be shut-off before the demolition work is started.
- (viii) If a structure to be demolished has been partially wrecked by fire explosion or other catastrophe, the walls and damaged roofs should be braced suitably.
- (ix) No demolition work should be carried out at night especially when the structure to be demolished is in an inhabited area.

## \* FIRE SAFETY

Every year, many disasters occur due to fire in buildings which result in loss of life, property and documents. Due to shortage of space a number of high rise buildings are being constructed and the risk of fire hazards is much greater in such buildings. It may not be possible to completely eliminate fire hazards in high rise buildings equipped with modern amenities for comfortable living. However, by proper planning of buildings and by providing appropriate fire protection systems, fire hazards can be minimised.

## \* FIRE SAFETY IN BUILDINGS

For safety against fire hazards in buildings, early warning systems are installed to detect fire and give fire alarms so as to protect the building and its occupants. The early warning systems commonly used are:

(a) Smoke detector (for air-conditioned areas)

(b) Heat sensitive detector (for non-airconditioned areas)

These detectors are placed on each floor at suitable locations and are grouped to form a local panel on each floor. These panels are in turn connected to the main control panel with audio (sound) alarm and visual (light) indicators. These panels sound the alarm and alert the occupants in the event of fire hazards and enable them to vacate the building before much loss of life & property occurs.

For safety requirements in buildings, the under-mentioned IS codes may be followed:

(i) All buildings must be designed to satisfy fire safety requirements as per IS: 1256-1967, which specifies that all multistoreyed high rise buildings must have separate staircase at every 30 metre distance in addition to lifts and emergency fire escapes.



- (ii) Spacing of buildings should be in accordance with IS 11643-1960 so as to provide adequate protection against exposure hazards.
- (iii) Chimney flues and smoke pipes should be provided in accordance with IS:1645-1960 for fire safety.
- (iv) Fire safety of electrical installations in buildings should be as per IS:1646-1982.
- (v) The design of different structural elements should taken into account the fire resistance ratings of these elements as per IS:1641-1960.
- (vi) For non-electric lighting equipment, oil and gas heaters, reference should be made to IS:1647:1960.

The important principles in the design of fire resistant buildings are to use such materials which do not collapse immediately in the event of fire and to provide adequate emergency escapes for use during fire hazards. During construction, fire hazards due to electric short-circuiting can be avoided by proper wiring. Naked and loose electric wiring should be completely prohibited. Open fires should be prohibited on construction sites where inflammable materials are stored (or) stacked.

## \* PILING:

- (i) There are three types of pile foundations according to their construction methods:
- Driven piles.
  - Cast-in-situ piles.
  - Driven and cast-in-situ piles.

### Driven pile foundations:

It can be made from concrete, steel or timber. These piles are prefabricated before placing at the construction site. When driven piles are made of concrete, they are precast. These piles are driven using a pile hammer.

When these piles are driven into the granular soils, they



displace the equal volume of soil. This helps in compaction of soil around the sides of piles and results in the densification of soil. The piles which compact the soil adjacent to it is also called as compaction of pile. This compaction of soil increases its bearing capacity.

Saturated silty soils and cohesive soils have poor drainage capability. Thus these soils are not compacted when driven piles are drilled through it. The water have to be drained for the soil to be compacted. Thus stresses are developed adjacent to the piles have to be borne by pore water only. This results in increase in pore water pressure and decrease in bearing capacity of the soil.

#### \* CAST-IN-SITU PILE FOUNDATIONS;

These are concrete pile. These piles are constructed by drilling holes in the ground to the required depth and then filling the hole with concrete. Reinforcements are also used in the concrete as per the requirements. These piles are of small diameter compared to drilled piers. Cast-in-situ piles are straight bored piles or with one or more bulbs at intervals are casted. The piles with one or more bulbs are called as under-reamed piles.

#### \* DRIVEN AND CAST-IN-SITU PILES;

Driven and cast-in-situ piles have the advantages of both driven and cast-in-situ piles. The procedure of installing a driven and cast-in-situ pile is as follows;

A steel shell of diameter of pile is driven into the ground with the aid of a mandrel inserted into the shell. After driving the shell, the mandrel is removed and concrete is poured in the shell. The shell is made of corrugated and reinforced thin sheet steel (mono-tube-piles) or pipes (Armco welded pipes or common seamless pipes). The piles of this type are called a shell type piles.

The shell-less type is formed by withdrawing the shell while the concrete is being placed. In both the types of piles the bottom of the shell is closed with a conical tip which can be separated from the shell. By driving the concrete out of the shell an enlarged bulb may be formed in both the types of piles. Franki piles are of this type. In some cases the shell will be left in place and the tube is concreted. This type of pile is very much used in piling over water.

\* FORMWORK; The concrete is contained in a timber or a steel casing for a certain period after its placing. This casing is known as the shuttering, formwork or moulds and it is to be removed when the concrete has hardened sufficiently to support its own weight.

Following precautions should be taken for the formwork of concrete;

- (1) The formwork should be designed in such a way that it can be easily removed and used again.
- (2) The formwork should be fixed in such a way that the least hammering is required for its removal. Otherwise it may injure the concrete.
- (3) The inside surface of formwork should be coated with crude oil or soft soap solution. This will make removal of the formwork easy.
- (4) The formwork should be sufficiently strong to bear the dead load of wet concrete as well as the impact of ramming or vibrating the concrete. The over-estimation of loads results in expensive formwork and the under-estimation of loads results in the failure of formwork.
- (5) It is desirable to bring down the cost of formwork to a minimum consistent with safety. The various steps such as reduction in number of irregular shapes of bords, use of component parts of commercial sizes, putting the formwork in use again as early as possible, etc., may be taken to effect economy in the formwork.

6) The formwork should be so arranged that there is a minimum of leakage through the joints. This is achieved by providing tight joints between adjacent sections of the formwork.

### \* FABRICATION AND ERECTION:

Metal fabrication is the building of metal structures by cutting, bending, and assembling processes. It is a value added process that involves the construction of machines and structures from various raw materials.

A fabricator's work starts from the point of procurement of raw materials including fasteners and ends with the dispatch of the fabricated items to site for erection.

In order to ensure that the fabrication can be carried out in accordance with the drawings, it is necessary that inspection and checking is carried out in accordance with an agreed Quality Assurance plan (QAP). The plan should elaborate on checks and inspections of the raw materials and also of the components as they are fabricated, joined etc.,

During the last two decades, fabrication activities have increased steadily in yards adjacent to work. In the absence of controlled environment (as in an organised workshop), the quality of workmanship of such fabrication is likely to suffer. It has therefore become all the more important to motivate the fabricators to appreciate the usefulness of Quality assurance plans and introduce the system in all their works and at site as well.

### \* ERECTION:

Erection is the process by which the fabricated structural members are assembled together to form the skeletal structure.



Steps that are involved in the erection process:

- \* Receiving material from the shop and temporarily stacking them, if necessary.
- \* Lifting and placing the member and temporarily holding in place
- \* Temporarily bracing the system to ensure stability during erection
- \* Aligning and permanently connecting the members by bolting or welding.
- \* Connecting cladding to the steel structural skeleton.
- \* Application of a final coat of painting.

Guidance for handling and storage for material shall be obtained from IS : 7969 (1975). The fabrication<sup>at</sup> shop or site should be so planned that units to be handled weigh nearly the same. The erection drawing should reach the site of construction well in advance to plan the erection sequence and material handling. Erection should be carried out with the help of maximum possible mechanisation. Normally anyone or more of the material handling systems, such as tower crane, crane mounted on rails, crawling crane, pneumatic tire mounted crane, and derrick crane may be used for handling the materials. Details of the above said erection equipments can be found in any previous chapters on construction equipment.

A variety of methods can be employed for the erection of a structure, normally, the selection of the method is influenced by the type of the structure, site conditions, equipment, quality of skilled labour etc., available to the erector.

## \* Tractors:

This equipment is a self-propelled machine which is used mainly to exert a powerful tractive force for pulling other machines. When the tractor is not required for hauling other machines, it can be easily converted to serve as bulldozer, angle-dozer, etc. The tractors are used for agricultural operations such as hoeing, tilling, harvesting, etc. When tractors are equipped with shovels, they can even be used for the mining operations.

The tractor may be crawler mounted or wheel mounted. In the former type, the tractor is supported on endless chain of plates and it is used for rough and uneven ground. In the latter type, the tractor is supported on wheels and it is used for even ground.